

One-touch fittings—tube-tube type

Ordering code

Same diameter type fittings **PE 6 □**

① ② ③

① Model				② Port size	③ Standard color		
PM: Bulkhead union 	PE: Union tee 	PP: Plug 	PV: Union elbow 	4: Φ4mm 6: Φ6mm 8: Φ8mm 10: Φ10mm 12: Φ12mm	Standard color	Specification	Adaptable model
PLM: Bulkhead male elbow 	PY: Union "Y" 	PZ: Cross 	PU: Straight union 		Blank: Gray	Release button: Gray Body: Gray	PM Others
					D: Black	Release button: Black Body: Black	PM Others

Different diameter type fittings **PEG 6 - 4 □**

① ② ③ ④

① Model					② Port size I	③ Port size II	④ Standard color	
PG: Different diameter straight 	PZG: Different diameter cross 	PEW: Different diameter tee 	PYW: Different diameter union "Y" 	PGJ: Plug-in reducer 	4: Φ4mm 6: Φ6mm 8: Φ8mm 10: Φ10mm 12: Φ124mm	4: Φ4mm 6: Φ6mm 8: Φ8mm 10: Φ10mm	Standard color	Specification
PEG: Different diameter tee 	PKG: Reducer triple branch union 	PHK: Universal reducer triple branch union 	PHD: Universal reducer four branch union 				Blank: Gray	Release button: Gray Body: Gray
							D: Black	Release button: Black Body: Black

Specification

Operating pressure range	0~10kgf/cm²(0~1.0MPa)
Negative pressure	-750mmHg(10Torr)
Proof pressure	1.5MPa
Ambient and fluid temperature (°C)	-20~70
Applicable tubing	Soft nylon or polyurethane
Color	Grey/black

Product feature

1. Variable models can be widely used in every kind of pneumatic systems.
2. High circulation performance: bear the same flow with the volume of the tubing inside diameter.
3. Connect tubing easily and conveniently. The tubing connection portion is safe and durable.
4. The threaded portion is covered with sealant and the M5 thread is attached with a sealing gasket to prevent air leakage over the connection thread portion.

Inner structure

No.	Item	Material
1	Release button	POM
2	Guide	Aluminum alloy
3	Spring gasket	Stainless steel
4	Chuck	POM
5	O-ring	NBR
6	Body	Aluminum alloy
7	Rubber washer	NBR
8	Nut	Aluminum alloy

Table for interface port and tube O.D.

Product series	Port size I	Port size II			
		Φ4	Φ6	Φ8	Φ10
PG PGJ	Φ4				
	Φ6	●			
	Φ8	●	●		
	Φ10		●	●	
	Φ12			●	●
PEG PEW PYW	Φ4				
	Φ6	●			
	Φ8		●		
	Φ10			●	
	Φ12			●	●
PZG	Φ4				
	Φ6	●			
	Φ8		●		
	Φ10			●	
	Φ12				●
PKG	Φ4				
	Φ6	●			
	Φ8		●		
	Φ10			●	
	Φ12				●
PHK PHD	Φ4				
	Φ6				
	Φ8		●		
	Φ10			●	
	Φ12				●
Product series	Port size				
PE, PY, PV, PU PM, PLM, PP, PZ	Φ4	Φ6	Φ8	Φ10	Φ12
	●	●	●	●	●

One-touch fittings—tube-tube type

Dimensions

PE Series

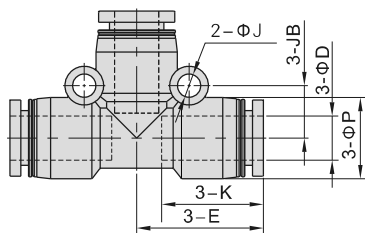

Model\Item	ΦD	ΦP	K	E	ΦJ	JB	Weight(g)
PE4	4	9	14	17	3.2	6.5	3.1
PE6	6	12.5	16.5	20	3.2	8	6.1
PE8	8	15	18.5	23	4.3	9.5	8.8
PE10	10	18	21	26.5	4.3	11	13.8
PE12	12	21	23	30	4.3	13	21

PU Series

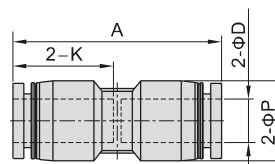

Model\Item	ΦD	ΦP	K	A	Weight(g)
PU4	4	9	14	29.5	1.7
PU6	6	12.5	16.5	34	3.6
PU8	8	15	18.5	38.5	5
PU10	10	18	21	43	8.1
PU12	12	21	23	47	12

PY Series

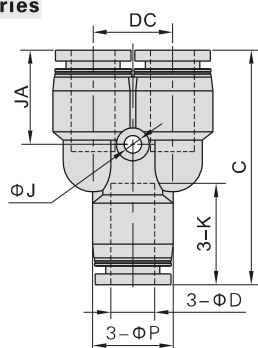

Model\Item	ΦD	ΦP	C	K	ΦJ	JA	DC	Weight(g)
PY4	4	9	31.5	14	3.2	13	10	3
PY6	6	12.5	37	16.5	3.2	15.5	12	6
PY8	8	15	42.5	18.5	3.2	17	14.5	8.6
PY10	10	18	48.5	21	4.3	19.5	18	14
PY12	12	21	54.5	23	4.3	21	20.5	21.2

PM Series

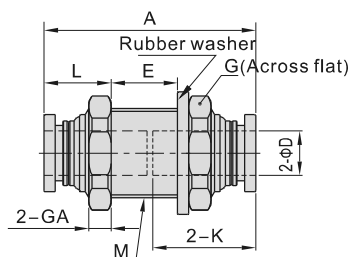

Model\Item	ΦD	M	A	K	L	E	GA	G	Weight(g)
PM4	4	M12X1	29	14	10	7	4	14	6.2
PM6	6	M14X1	34	16.5	10.5	11	4	17	9.5
PM8	8	M16X1	38	18.5	11.5	13	4	19	15.7
PM10	10	M20X1	43	21	12.5	16	5	24	22.5
PM12	12	M22X1	46.5	23	13.5	17.5	6	27	29.5

PV Series

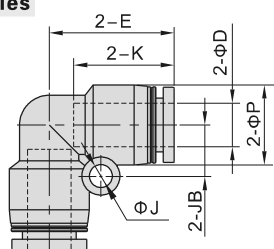

Model\Item	ΦD	ΦP	K	E	ΦJ	JB	Weight(g)
PV4	4	9	14	17	3.2	6.5	1.9
PV6	6	12.5	16.5	20	3.2	8	4.2
PV8	8	15	18.5	23	4.3	9.5	6
PV10	10	18	21	26.5	4.3	11	9.3
PV12	12	21	23	30	4.3	13	14.6

PLM Series

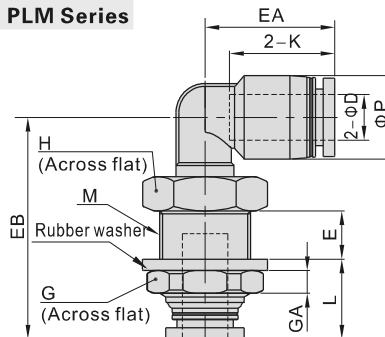

Model\Item	ΦD	ΦP	M	L	E	K	EA	EB	GA	G	H	Weight(g)
PLM4	4	9	M12X1	12	7.5	14	17	31	4	14	14	7.5
PLM6	6	12.5	M14X1	12.5	8.5	17	20	35.5	4	17	17	12.1
PLM8	8	15	M16X1	13.5	9	18.5	23	39	4	19	19	16.6
PLM10	10	18	M20X1	14.5	11	21	25.5	44.5	5	24	22	26.2
PLM12	12	21	M22X1	15.5	11	23	29.5	48	6	27	24	34