

Solenoid Valve for Pneumatic System Solenoid Valve **SVB Series**

- *Focusing on basic performance. Providing good cost-performance.*
- *Push-Lock Manual Button installed. Improved efficiency of maintenance.*
- *2 selections of connector lead-out direction: (Top and Side)*

Construction

- 2-Position, 5-Port, Single Solenoid Valve (Stand-alone unit , For 3- & 5-port mixed mountable manifold)

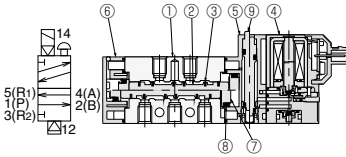

No.	Part	Material (Treatment)
1	Valve Body	Aluminum Alloy
2	Spool	Aluminum Alloy
3	Spool Seal Rubber	NBR
4	Pilot Valve Assy	
5	Intermediate Block	PBT
6	End Block	PBT
7	Piston	POM
8	Y-shaped Seal Rubber	NBR
9	Manual Button	POM

- 2-Position, 5-Port, Double Solenoid Valve (Stand-alone unit , For 3- & 5-port mixed mountable manifold)

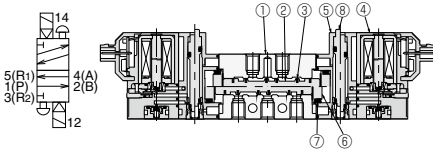

No.	Part	Material (Treatment)
1	Valve Body	Aluminum Alloy
2	Spool	Aluminum Alloy
3	Spool Seal Rubber	NBR
4	Pilot Valve Assy	
5	Intermediate Block	PBT
6	Piston	POM
7	Y-shaped Seal Rubber	NBR
8	Manual Button	POM

- 3-Position, 5-Port, Closed Center (Stand-alone unit, For 3- & 5-port mixed mountable manifold)

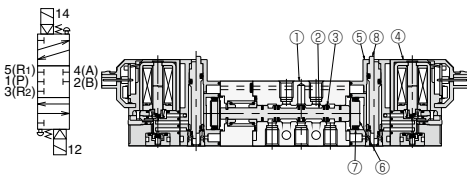

No.	Part	Material (Treatment)
1	Valve Body	Aluminum Alloy
2	Spool	Aluminum Alloy
3	Spool Seal Rubber	NBR
4	Pilot Valve Assy	
5	Intermediate Block	PBT
6	Piston	POM
7	Y-shaped Seal Rubber	NBR
8	Manual Button	POM

- 2-Position, 3-Port, Single Solenoid Valve (For 3- & 5-port mixed mountable manifold)

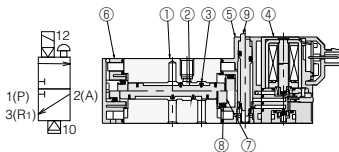

No.	Part	Material (Treatment)
1	Valve Body	Aluminum Alloy
2	Spool	Aluminum Alloy
3	Spool Seal Rubber	NBR
4	Pilot Valve Assy	
5	Intermediate Block	PBT
6	End Block	PBT
7	Piston	POM
8	Y-shaped Seal Rubber	NBR
9	Manual Button	POM

● 2-Position,3-Port, Double Solenoid Valve (For 3- & 5-port mixed mountable manifold)

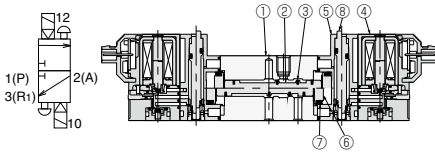

No.	Part	Material (Treatment)
1	Valve Body	Aluminum Alloy
2	Spool	Aluminum Alloy
3	Spool Seal Rubber	NBR
4	Pilot Valve Assy	
5	Intermediate Block	PBT
6	Piston	POM
7	Y-shaped Seal Rubber	NBR
8	Manual Button	POM

● 2-Position, 3-Port, Single Solenoid Valve (Stand-alone unit, For installation of 3-port)

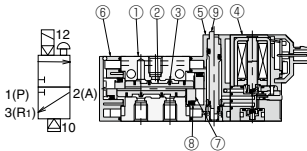

No.	Part	Material (Treatment)
1	Valve Body	Aluminum Alloy
2	Spool	Aluminum Alloy
3	Spool Seal Rubber	NBR
4	Pilot Valve Assy	
5	Intermediate Block	PBT
6	End Block	PBT
7	Piston	POM
8	Y-shaped Seal Rubber	NBR
9	Manual Button	POM

● 2-Position, 3-Port, Double Solenoid Valve (Stand-alone unit, For installation of 3-port)

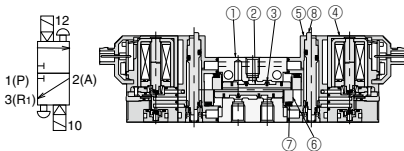

No.	Part	Material (Treatment)
1	Valve Body	Aluminum Alloy
2	Spool	Aluminum Alloy
3	Spool Seal Rubber	NBR
4	Pilot Valve Assy	
5	Intermediate Block	PBT
6	Piston	POM
7	Y-shaped Seal Rubber	NBR
8	Manual Button	POM

Model Designation of Stand-alone unit, Direct Piping Type (Example)

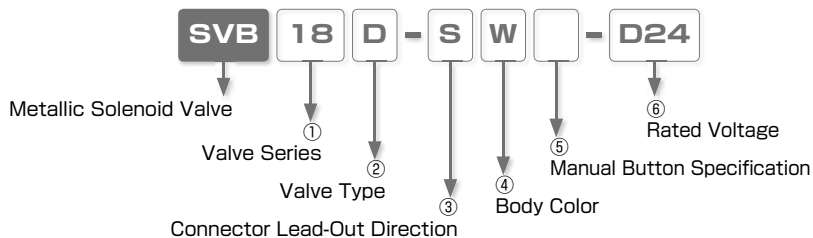

① Valve Series

- 10 : 10 Series (Valve width: 10mm)
- 15 : 15 Series (Valve width: 15mm)
- 18 : 18 Series (Valve width: 18mm)
- 22 : 22 Series (Valve width: 22mm)

② Valve Type

Code	Position	No. of Port	Valve Type
S	2	5	Single Solenoid
D	2	5	Double Solenoid
A	3	5	Closed Center
R	3	5	Exhaust Center
P	3	5	Pressure Center

Code	Position	No. of Port	Valve Type
J	2	3	Single Solenoid / Normally Closed(*1)
L	2	3	Single Solenoid / Normally Open(*1)
Y	2	3	Double Solenoid(*1)
M	2	3	Single Solenoid / Normally Closed(*2)
N	2	3	Single Solenoid / Normally Open(*2)
Z	2	3	Double Solenoid(*2)

* 1. Valve specified For 3- & 5-port mixed mountable manifold. Available only with 15 and 18 Series.

* 2. Available only with 15 and 18 Series.

* 3. For 10 and 22 Series, only S, D, A, R and P are selectable.

③ Connector Lead-Out Direction

- S : Top
- L : Side

④ Body Color (* Light Gray is the only option for 10 Series)

- B : Silver
- W : Light Gray

⑤ Manual Button Specification (* "No Code" is the only option for 10 Series)

No Code : Tool Operation Type

H : Manual Operation Type

* Only "No code" shall be selected for SVB 10 series since the button can be operated by either a tool or fingers.

⑥ Rated Voltage

Code	D24	A100	A110	A200	A220
Rated Voltage	DC24V	AC100V	AC110V	AC200V	AC220V

* 10 Series has DC24V or AC100V selection only.

■ Model Designation of 10 Series Manifold Piping Type (Example)

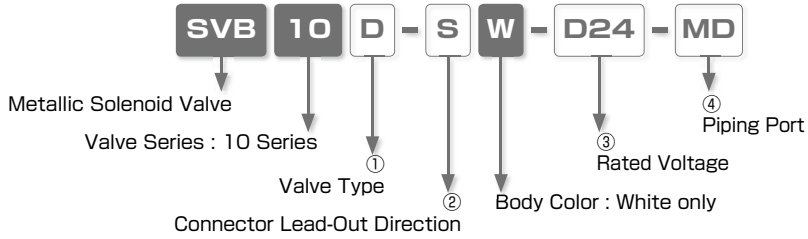

① Valve Type

Code	Position	No. of Port	Valve Type
S	2	5	Single Solenoid
D	2	5	Double Solenoid
A	3	5	Closed Center
R	3	5	Exhaust Center
P	3	5	Pressure Center

② Connector Lead-Out Direction

S : Top
 L : Side

③ Rated Voltage

D24 : DC24V
 A100 : AC100V

④ Piping Port (selectable for 10 Series only)

MD : Direct Piping Port
 MB : Manifold Base Piping Port

Model Designation of Valve Piping Type (Example)

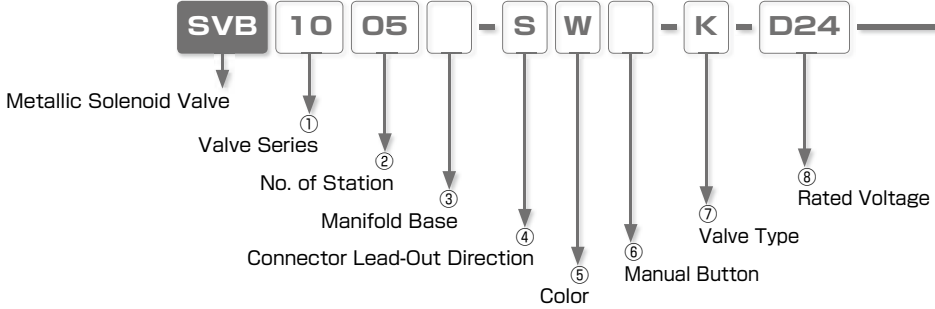

① Valve Series

- 10 : 10 Series (Valve width: 10mm)
- 15 : 15 Series (Valve width: 15mm)
- 18 : 18 Series (Valve width: 18mm)
- 22 : 22 Series (Valve width: 22mm)

② No. of Station

Code	02	03	04	05	06	07	08	09	10
No. of Station	2	3	4	5	6	7	8	9	10

③ Manifold Base (available for 15 and 18 Series only)

- No Code** : 3- & 5-port mixed mountable manifold
- Y** : 3-port valve-dedicated manifold.

④ Connector Lead-Out Direction

- S** : Top
- L** : Side

⑤ Body Color (* Light Gray is the only option for 10 Series)

- B** : Silver
- W** : Light Gray

⑥ Manual Button Specification (* "No Code" is the only option for 10 Series)

- No Code** : Tool Operation Type
- H** : Manual Operation Type

* Only "No code" shall be selected for SVB 10 series since the button can be operated by either a tool or fingers.

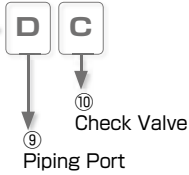

⑦ Valve Type

Code	Position	No. of Port	Valve Type
S	2	5	Single Solenoid
D	2	5	Double Solenoid
A	3	5	Closed Center
R	3	5	Exhaust Center
P	3	5	Pressure Center
J	2	3	Single Solenoid, Normally Closed(*1)
L	2	3	Single Solenoid, Normally Open(*1)
Y	2	3	Double Solenoid(*1)

Code	Position	No. of Port	Valve Type
M	2	3	Single Solenoid, Normally Closed(*2)
N	2	3	Single Solenoid, Normally Open(*2)
Z	2	3	Double Solenoid(*2)
K	Combinations of each valve (Please specify on the order form on p.39**)		
B	Block Plate		

* 1. Valve specified for 3- & 5-port mixed mountable manifold base. Available only with 15 and 18 Series.

* 2. Available only with 15 and 18 Series.

* 3. For 10 and 22 Series, only S, D, A, R and P are selectable.

⑧ Rated Voltage

Code	D24	A100	A110	A200	A220
Rated Voltage	DC24V	AC100V	AC110V	AC200V	AC220V

* 10 Series has DC24V or AC100V selection only.

⑨ Piping Port (*Selectable for 10 Series only)

D : Direct Piping port

B : Manifold base Piping port

⑩ Check Valve Specification (*Selectable for 10 Series only)

No Code : Without Check Valve

C : With Check Valve

Model Designation of Manifold base alone (Example)

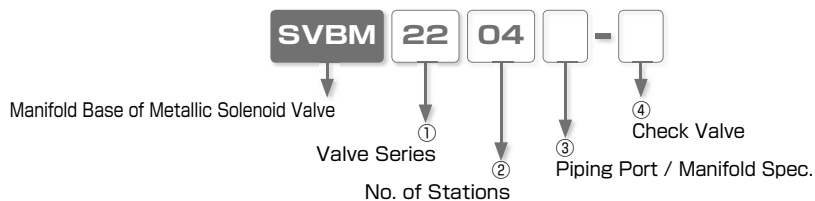

① Valve Series

- 10 : 10 Series (Valve width: 10mm)
- 15 : 15 Series (Valve width: 15mm)
- 18 : 18 Series (Valve width: 18mm)
- 22 : 22 Series (Valve width: 22mm)

② No. of Stations

Code	02	03	04	05	06	07	08	09	10
No. of Stations	2	3	4	5	6	7	8	9	10

③ Piping Port (* For 10 Series) • Manifold Spec. (* For 15, 18 and 22 Series)

- D : Direct Piping port
- No Code : 3- & 5-port mixed mountable manifold base
- B : Manifold Base Piping port
- Y : 3-port valve-dedicated manifold

④ Check Valve Specification (* Selectable for 10 Series only)

- No Code : Without Check Valve
- C : With Check Valve

Model Designation of Block Plate (Example)

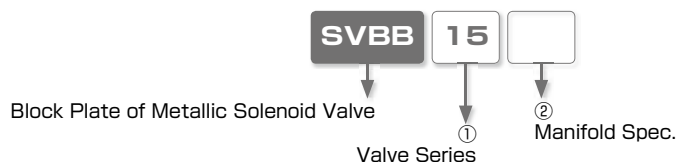

① Valve Series

- 10 : 10 Series (Valve width: 10mm)
- 15 : 15 Series (Valve width: 15mm)
- 18 : 18 Series (Valve width: 18mm)
- 22 : 22 Series (Valve width: 22mm)

② Manifold Spec. (For 15, 18 and 22 Series only)

- No Code : 3- & 5-port mixed mountable manifold base
- Y : 3-port valve-dedicated manifold

Code Example

Model	Series	No. of Stations	Manifold Spec.	Connector Lead-Out Direction	Body Color	Manual Button	Mounted Valve Type	Rated Voltage	Piping Port	Check Valve
	①	②	③	④	⑤	⑥	⑦	⑧	⑨ *	⑩ *
SVB	18	O7		L	B		K	D24		

Marking * are selectable for 10 Series only

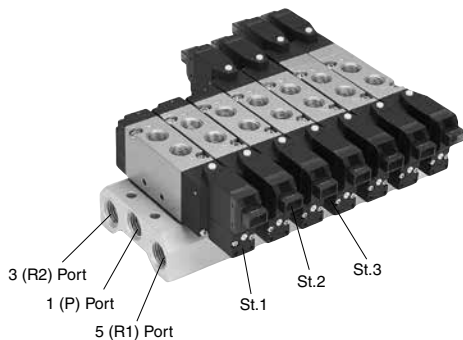

Station No.	Valve Type
St.1	S
St.2	S
St.3	S
St.4	D
St.5	D
St.6	R
St.7	R
St.8	
St.9	
St.10	

* Station mounting order: St.1, St.2, St.3.. from left side as having 5 (R1) port at front as the above picture.

Order Form: Solenoid Valve SVB Series

To: NIHON PISCO CO., Ltd. _____

From : _____

Name : _____

Order No. : _____

Date : _____

Requested EX-W PISCO Date : _____ Quantity : _____

Model	Series	No. of Stations	Manifold Spec.	Connector Lead-Out Direction	Body Color	Manual Button	Mounted Valve Type	Rated Voltage	Piping Port	Check Valve
	①	②	③	④	⑤	⑥	⑦	⑧	⑨ *	⑩ *
SVB				-			-			

Marking * are selectable for 10 Series only

Station No.	Mounted Valve Type
St.1	
St.2	
St.3	
St.4	
St.5	
St.6	
St.7	
St.8	
St.9	
St.10	

Specifications of Pilot Valve

10 Series

Item	Rated Voltage	
	DC24V	AC100V
Operating system	Pilot Valve	
Valve Structure	Poppet Valve (Elastic Seal)	
Tolerance of Voltage Range	DC21.6 ~ DC26.4V	AC90 ~ AC110V
Power Consumption (with LED)	0.55W	1VA
Surge Protection Circuit	Surge Absorber	Bridge Diode
Manual Operation	Push-Lock Button	
Connector Lead-Out Direction	Connector (Straight type: Top / Elbow type: Side)	
Operation Indicator	LED	

15, 18 and 22 Series

Item	Rated Voltage				
	DC24V	AC100V	AC110V	AC200V	AC220V
Operating system	Pilot Valve				
Valve Structure	Poppet Valve (Elastic Seal)				
Tolerance of Voltage Range	DC21.6 ~ DC26.4V	AC90 ~ AC110V	AC99 ~ AC121V	AC180 ~ AC220V	AC198 ~ AC242V
Power Consumption (with LED)	0.8W	1VA	1.1VA	2VA	2.2VA
Surge Protection Circuit	Surge Absorber	Bridge Diode			
Manual Operation	Push-Lock Button				
Connector Lead-Out Direction	Connector (Straight type: Top / Elbow type: Side)				
Operation Indicator	LED				

Specifications of 10 Series Main Valve

Item	Model	Stand-alone unit Type			Manifold Type		
		SVB10S	SVB10D	SVB10A SVB10R SVB10P	SVB10S-M □	SVB10D-M □	SVB10A-M □ SVB10R-M □ SVB10P-M □
Fluid Medium	Air						
Operating Pressure Range	0.2 ~ 0.7MPa		0.3 ~ 0.7MPa	0.2 ~ 0.7MPa		0.3 ~ 0.7MPa	
Pressure Resistance	1.05MPa						
Operating Temp. Range	5 ~ 50°C						
Installing Direction	No Restriction (*1)						
Operating system	Indirectly activated Pneumatic Operation by Pilot Valve						
Port Thread Size	M5 × 0.8			M5 × 0.8			
Valve Structure	Spool Valve (Elastic Seal)						
No. of Position	2-Position		3-Position	2-Position		3-Position	
No. of Port	5-Port						
Valve Function	Single	Double		Single	Double		
Response	→ ON	15msec	12msec	15msec(*3)	15msec	12msec	15msec(*3)
Time (※ 2)	→ OFF	20msec	12msec	25msec(*3)	20msec	12msec	25msec(*3)
Max. Operation Cycle	5Hz						
Min. Excitation Time		50msec			50msec		
Lubrication	Not Required						
Flow Characteristics	1(P)→ 4(A), 2(B)	C (*4)	0.6	0.8	0.36	0.4	
		S (*5)	3.0 (0.16)	4.0 (0.22)	1.8 (0.10)	2.0 (0.11)	
	Neutral Position	C (*4)		0.4		0.32	
		S (*5)		2.0 (0.11)		1.6 (0.09)	
	4(A), 2(B)→ 5(R1), 3(R2)	C (*4)	0.4	0.8	0.32	0.4	
		S (*5)	2.0 (0.11)	4.0 (0.22)	1.6 (0.09)	2.0 (0.11)	
Neutral Position	C (*4)		0.4		0.24		
	S (*5)		2.0 (0.11)		1.2 (0.07)		

*1. Refer to "Warning" on page 77 (Detailed Safety Instructions).

*2. Values at 0.5MPa of supply.

*3. Response Time for 3-Position represents the value from Neutral Position to ON and from ON to Neutral Position (OFF).

*4. C: Sonic Conductance C (dm³/(s·bar))

*5. S: Effective Sectional Area S (mm² (CV))

10 Series Cylinder Speed Table

Cylinder Speed (mm/s)	Cylinder Tube bore (mm)			
	φ 20	φ 25	φ 32	φ 40
100				
200				
300				
400				
500				
600				
700				

Note) ● The cylinder average speed is referential at 0.5MPa of pressure, 30% of load factor and 1m of tube length.

● The cylinder speed can vary according to the configuration of piping and fittings.

● The data in the above table represents the value when ø6mm Push-In Fitting is used on 4(A) and 2(B) ports of SVB10D.

Specifications of 15 Series Main Valve

Model	SVB15S	SVB15D	SVB15A SVB15R SVB15P	SVB15J SVB15L SVB15M SVB15N	SVB15Y SVB15Z	
Item						
Fluid Medium	Air					
Operating Pressure Range	0.15 ~ 0.7MPa		0.2 ~ 0.7MPa		0.15 ~ 0.7MPa	
Pressure Resistance	1.05MPa					
Operating Temp. Range	5 ~ 50°C					
Installing Direction	No Restriction (*1)					
Operating system	Indirectly activated pneumatic operation by pilot valve					
Port Thread Size	M5 × 0.8 (*2)					
Valve Structure	Spool Valve (Elastic Seal)					
No. of Position	2-Position		3-Position		2-Position	
No. of Port	5-Port			3-Port		
Valve Function	Single	Double		Single	Double	
Response Time	15msec	12msec		15msec	12msec	
Max. Operation Cycle	5Hz					
Min. Excitation Time	50msec				50msec	
Lubrication	Not Required					
Flow Characteristics	C (*3)	0.68		0.74	0.68	
	S (*4)	3.4 (0.18)		3.7 (0.20)	3.4 (0.18)	
	Neutral Position	C (*3)			0.64	
		S (*4)			3.2 (0.17)	

*1. Refer to "Warning" on page 77 (Detailed Safety Instructions).

*2. SVB15J, L, and Y are valves to mount on a manifold base so that there is no thread cutting on 1(P), 5(R1) and 3(R2) ports.

*3. C: Sonic Conductance C(dm3/s-bar)

*4. S: Effective Sectional Area S (mm² (CV)). Values are based on the calculation from 1(P) to 4(A).

15 Series Cylinder Speed Table

Cylinder Speed (mm/s)	Cylinder Tube bore (mm)					
	φ 20	φ 25	φ 32	φ 40	φ 50	φ 63
100						
200						
300						
400						
500						
600						
700						
800						

Note) ● The cylinder average speed is referential at 0.5MPa of pressure, 30% of load factor and 1m of tube length.

● The cylinder speed can vary according to the configuration of piping and fittings.

● The data in the above table represents the value when φ6mm Push-In Fitting is used on 4(A) and 2(B) ports of SVB15D.

Specifications of 18 Series Main Valve

Model	SVB18S	SVB18D	SVB18A SVB18R SVB18P	SVB18J SVB18L SVB18M SVB18N	SVB18Y SVB18Z	
Item						
Fluid Medium	Air					
Operating Pressure Range	0.15 ~ 0.7MPa		0.2 ~ 0.7MPa	0.15 ~ 0.7MPa		
Pressure Resistance	1.05MPa					
Operating Temp. Range	5 ~ 50°C					
Installing Direction	No Restriction (*1)					
Operating system	Indirectly activated Pneumatic Operation by Pilot Valve					
Port Thread Size	Rc1/8 (*2)					
Valve Structure	Spool Valve (Elastic Seal)					
No. of Position	2-Position		3-Position	2-Position		
No. of Port	5-Port			3-Port		
Valve Function	Single	Double		Single	Double	
Response Time	20msec	15msec		20msec	15msec	
Max. Operation Cycle	5Hz					
Min. Excitation Time		50msec			50msec	
Lubrication	Not Required					
Flow Characteristics	C (*3)	2.6		2.6	2.6	
	S (*4)	13 (0.70)		13 (0.70)	13 (0.70)	
	Neutral Position	C (*3)			1.04	
		S (*4)			5.2 (0.28)	

*1. Refer to "Warning" on page 77 (Detailed Safety Instructions).

*2. SVB18J, L, and Y are valves to mount on a manifold base so that there is no thread cutting on 1(P), 5(R1) and 3(R2) ports.

*3. C: Sonic Conductance C (dm³/(s·bar))

*4. S: Effective Sectional Area S (mm² (CV)). Values are based on the calculation from 1(P) to 4(A).

18 Series Cylinder Speed Table

Cylinder Speed (mm/s)	Cylinder Tube bore (mm)							
	φ 20	φ 25	φ 32	φ 40	φ 50	φ 63	φ 80	φ 100
100								
200								
300								
400								
500								
600								
700								
800								
900								
1000								
1100								

Note) ● The cylinder average speed is referential at 0.5MPa of pressure, 30% of load factor and 1m of tube length.

● The cylinder speed can vary according to the configuration of piping and fittings.

● The data in the above table represents the value when ø8mm Push-In Fitting is used on 4(A) and 2(B) ports of SVB18D.

Specifications of 22 Series Main Valve

Model		SVB22S	SVB22D	SVB22A SVB22R SVB22P
Item				
Fluid Medium		Air		
Operating Pressure Range		0.2 ~ 0.7MPa		0.3 ~ 0.7MPa
Pressure Resistance		1.05MPa		
Operating Temp. Range		5 ~ 50°C		
Installing Direction		No Restriction (*1)		
Operating system		Indirectly activated Pneumatic Operation by Pilot Valve		
Port Thread Size		1(P) · 4(A) · 2(B)Port : Rc1/4, 5(R1) · 3(R2)Port : Rc1/8		
Valve Structure		Spool Valve (Elastic Seal)		
No. of Position		2-Position		3-Position
No. of Port		5-Port		
Valve Function		Single	Double	
Response Time		25msec	18msec	25msec
Max. Operation Cycle		5Hz		
Min. Excitation Time		50msec		
Lubrication		Not Required		
Flow Characteristics	C (*2)	3.6		3
	S (*3)	18 (0.98)		15 (0.81)
	Neutral Position C (*2)			2.6
	Neutral Position S (*3)			13 (0.70)

*1. Refer to "Warning" on page 77 (Detailed Safety Instructions).

*2. C: Sonic Conductance C (dm³/s-bar)

*3. S: Effective Sectional Area S (mm² (CV)). Values are based on the calculation from 1(P) to 4(A).

22 Series Cylinder Speed Table

Cylinder Speed (mm/s)	Cylinder Tube bore (mm)								
	φ 20	φ 25	φ 32	φ 40	φ 50	φ 63	φ 80	φ 100	φ 125
100									
200									
300									
400									
500									
600									
700									
800									
900									
1000									
1100									

Note) ● The cylinder average speed is referential at 0.5MPa of pressure, 30% of load factor and 1m of tube length.

● The cylinder speed can vary according to the configuration of piping and fittings.

● The data in the above table represents the value when φ10mm Push-In Fitting is used on 4(A) and 2(B) ports of SVB22D

Weight List

● SVB10 Series

Valve Type		Weight (g)	Manifold Base Alone of Direct Piping Type	Weight (g)	Manifold Base Alone	Weight (g)	
SVB 10S	Stand-alone unit	28.8	SVBM 1002-D	185.0	SVBM 1002-B	183.2	
	-MD	29.8		223.7		1003-B	221.0
	-MB	32.8		261.8		1004-B	258.2
SVB 10D	Stand-alone unit	43.2	1005-D	300.0	1005-B	295.6	
	-MD	44.2	1006-D	338.8	1006-B	333.4	
	-MB	47.2	1007-D	377.8	1007-B	371.5	
	Stand-alone unit	47.2	1008-D	415.5	1008-B	408.3	
SVB 10A	-MD	48.2	1009-D	451.8	1009-B	443.7	
	-MB	51.2	1010-D	492.8	1010-B	483.8	
SVB 10P	Stand-alone unit	47.2					
	-MD	48.2					
	-MB	51.2					
SVB 10R	Stand-alone unit	47.2					
	-MD	48.2					
	-MB	51.2					

● SVB15 Series

Valve Type		Weight (g)	Manifold Base Alone	Weight (g)	Manifold Base Alone	Weight (g)
SVB 15S		60	SVBM 1502	175	SVBM 1502Y	91
D		85	03	225	03Y	118
A		97	04	279	04Y	145
R		97	05	312	05Y	174
P		97	06	389	06Y	201
J		63	07	444	07Y	229
L		63	08	496	08Y	256
Y		87	09	548	09Y	285
M		52	10	607	10Y	310
N		52				
Z		76				
			Block Plate	Weight (g)	Block Plate	Weight (g)
			SVBB 15	9	SVBB 15Y	6

● SVB18 Series

Valve Type	Weight (g)
SVB 18S	82
D	107
A	119
R	119
P	119
J	91
L	91
Y	116
M	69
N	69
Z	94

Manifold Base Alone	Weight (g)
SVBM 1802	130
03	176
04	223
05	267
06	309
07	356
08	401
09	451
10	497
Block Plate	Weight (g)
SVBB 18	9

Manifold Base Alone	Weight (g)
SVBM 1802Y	130
03Y	176
04Y	221
05Y	264
06Y	312
07Y	355
08Y	403
09Y	440
10Y	493
Block Plate	Weight (g)
SVBB 18Y	9

● SVB22 Series

Valve Type	Weight (g)
SVB 22S	129
D	148
A	267
R	267
P	267

Manifold Base Alone	Weight (g)
SVBM 2202	192
03	261
04	326
05	390
06	455
07	523
08	590
09	654
10	721
Block Plate	Weight (g)
SVBB 22	18

Flow Characteristics

SVB15 Series

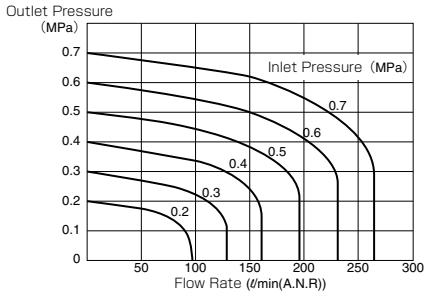

SVB 18 Series

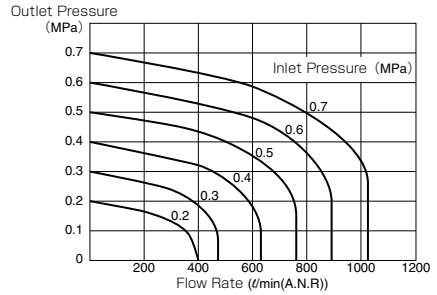

SVB 22 Series

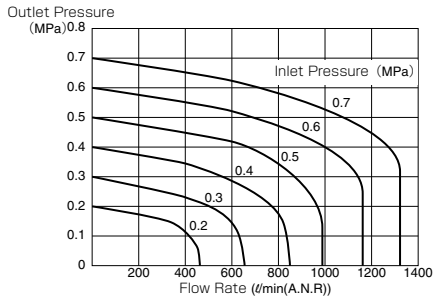

Standard Size List

Stand-alone Unit Type

Type	Page to refer	Port	Thread Size	Series				
				10	15	18	22	
[SVB] 2-Position, 5-Port Single Solenoid Valve	P.49	10 Series	4(A) 2(B)	M5 × 0.8(Female)	●	●	●	
	P.52	15 Series		Rc1/8				
	P.59	18 Series	1(P) 5(R1) 3(R2)	Rc1/4	●	●	●	●
	P.66	22 Series		M5 × 0.8(Female)				● ^{0.5} ● ⁽¹⁾

Type	Page to refer	Port	Thread Size	Series				
				10	15	18	22	
[SVB] 2-Position, 5-Port, Double Solenoid Valve	P.50	10 Series	4(A) 2(B)	M5 × 0.8(Female)	●	●	●	
	P.53	15 Series		Rc1/8				
	P.60	18 Series	1(P) 5(R1) 3(R2)	Rc1/4	●	●	●	●
	P.67	22 Series		M5 × 0.8(Female)				● ^{0.5} ● ⁽¹⁾

Type	Page to refer	Port	Thread Size	Series				
				10	15	18	22	
[SVB] 3-Position, 5-Port, Closed Center	P.51	10 Series	4(A) 2(B)	M5 × 0.8(Female)	●	●	●	
	P.54	15 Series		Rc1/8				
	P.61	18 Series	1(P) 5(R1) 3(R2)	Rc1/4	●	●	●	●
	P.68	22 Series		M5 × 0.8(Female)				● ^{0.5} ● ⁽¹⁾

Type	Page to refer	Port	Thread Size	Series				
				10	15	18	22	
[SVB] 3-Position, 5-Port, Exhaust Center	P.51	10 Series	4(A) 2(B)	M5 × 0.8(Female)	●	●	●	
	P.54	15 Series		Rc1/8				
	P.61	18 Series	1(P) 5(R1) 3(R2)	Rc1/4	●	●	●	●
	P.68	22 Series		M5 × 0.8(Female)				● ^{0.5} ● ⁽¹⁾

Type	Page to refer	Port	Thread Size	Series				
				10	15	18	22	
[SVB] 3-Position, 5-Port, Pressure Center	P.51	10 Series	4(A) 2(B)	M5 × 0.8(Female)	●	●	●	
	P.54	15 Series		Rc1/8				
	P.61	18 Series	1(P) 5(R1) 3(R2)	Rc1/4	●	●	●	●
	P.68	22 Series		M5 × 0.8(Female)				● ^{0.5} ● ⁽¹⁾

Type	Page to refer	Port	Thread Size	Series				
				10	15	18	22	
[SVB] 2-Position, 3-Port, Single Solenoid Valve, Normally Closed (5-port mixed mountable type)	P.55	15 Series	2(A)	M5 × 0.8(Female)	●	●		
	P.62	18 Series		Rc1/8				
			1(P) 3(R)	Piping Port Type		●	●	

Type	Page to refer	Port	Thread Size	Series				
				10	15	18	22	
[SVB] 2-Position, 3-Port, Single Solenoid Valve, Normally Open (5-port mixed mountable type)	P.55	15 Series	2(A)	M5 × 0.8(Female)	●	●		
	P.62	18 Series		Rc1/8				
			1(P) 3(R)	Piping Port Type		●	●	

Type	Page to refer	Port	Thread Size	Series				
				10	15	18	22	
[SVB] 2-Position, 3-Port, Double Solenoid Valve (5-port mixed mountable type)	P.56	15 Series	2(A)	M5 × 0.8(Female)	●	●		
	P.63	18 Series		Rc1/8				
			1(P) 3(R)	Piping Port Type		●	●	

Type	Page to refer	Port	Thread Size	Series				
				10	15	18	22	
[SVB] 2-Position, 3-Port, Single Solenoid Valve, Normally Closed	P.57	15 Series	2(A)	M5 × 0.8(Female)	●	●		
	P.64	18 Series		Rc1/8				
			1(P) 3(R)	M5 × 0.8(Female)		●	●	

Type	Page to refer	Port	Thread Size	Series				
				10	15	18	22	
[SVB] 2-Position, 3-Port, Single Solenoid Valve, Normally Open	P.57	15 Series	2(A)	M5 × 0.8(Female)	●	●		
	P.64	18 Series		Rc1/8				
			1(P) 3(R)	M5 × 0.8(Female)		●	●	

Type	Page to refer	Port	Thread Size	Series				
				10	15	18	22	
[SVB] 2-Position, 3-Port, Double Solenoid Valve	P.58	15 Series	2(A)	M5 × 0.8(Female)	●	●		
	P.65	18 Series		Rc1/8				
			1(P) 3(R)	M5 × 0.8(Female)		●	●	

Manifold Type

Type	Page to refer	Port	Thread Size
[SVB] 10 Series Valve Piping Type	P.69	4(A), 2(B) (1P, 5R1, 3R2)	M5 × 0.8(Female) Rc1/8

Type	Page to refer	Port	Thread Size
[SVB] 10 Series Manifold-block Piping Type	P.70	4(A), 2(B) (1P, 5R1, 3R2)	M5 × 0.8(Female) Rc1/8

Type	Page to refer	Port	Thread Size	Series			
				15	18	22	
[SVB] 3- & 5-port mixed mountable manifold-block	P.71	15 Series	4(A) 2(B)	M5 × 0.8(Female)	●	●	
	P.73	18 Series		Rc1/8			
			1(P) 5(R1) 3(R2)	M5 × 0.8(Female)		●	●

Type	Page to refer	Port	Thread Size	Series			
				15	18	22	
[SVB] 3-port Manifold-block	P.72	15シリーズ	2(A)	M5 × 0.8(Female)	●	●	
	P.74	18シリーズ		Rc1/8			
			1(P) 3(R)	M5 × 0.8(Female)		●	●

SOLENOID VALVE PREPARATION ACTUATOR PLUMBING/ROBOT PARTS HARMONIC SVB SERIES SV421 SERIES SVR SERIES SV420 SERIES SUBD CONNECTOR

10 Series Stand-alone Unit



2-Position, 5-Port, Single Solenoid Valve, Connector Lead-Out Direction: Top

Model Code

SVB 10S-SW □ - □

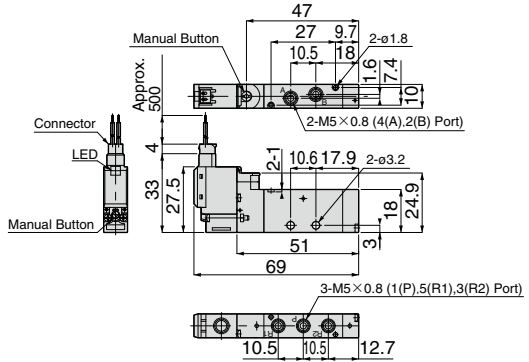
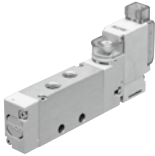

2-Position, 5-Port, Single Solenoid Valve, Connector Lead-Out Direction: Side

Model Code

SVB 10S-LW □ - □

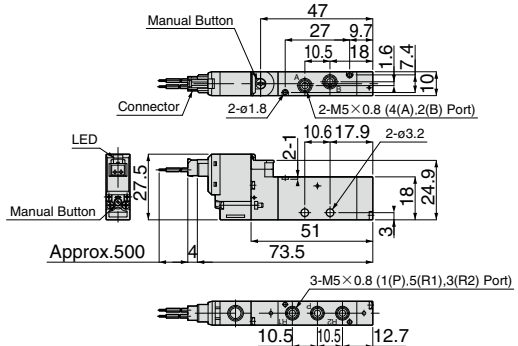

SVB 10 2-Position, 5-Port, Double Solenoid Valve, Connector Lead-Out Direction: Top

Model Code
SVB 10D-SW□-□

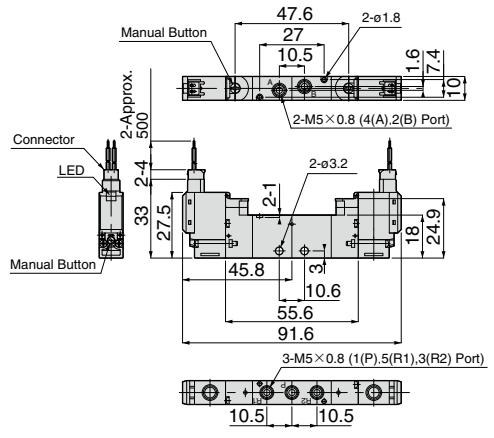

SVB 10 2-Position, 5-Port, Double Solenoid Valve, Connector Lead-Out Direction: Side

Model Code
SVB 10D-LW□-□

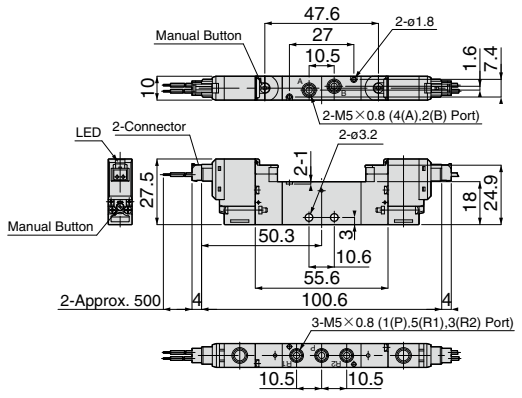

10 Series Stand-alone Unit



2-Position, 5-Port Solenoid Valve

- Closed Center
- Exhaust Center
- Pressure Center

Connector Lead-Out Direction: Top

Model Code

SVB 10A-SW □ - □

SVB 10R-SW □ - □

SVB 10P-SW □ - □

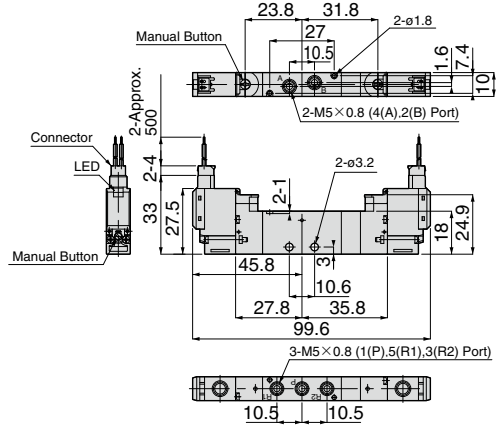
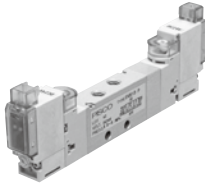

2-Position, 5-Port Solenoid Valve

- Closed Center
- Exhaust Center
- Pressure Center

Connector Lead-Out Direction: Side

Model Code

SVB 10A-LW □ - □

SVB 10R-LW □ - □

SVB 10P-LW □ - □

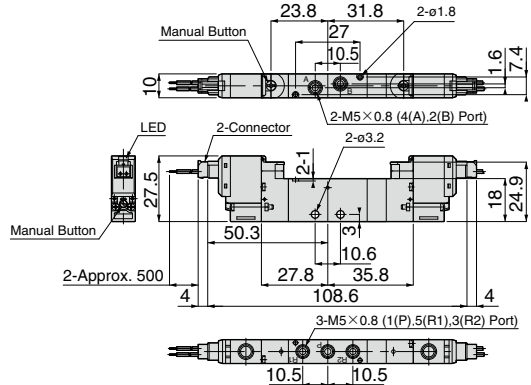
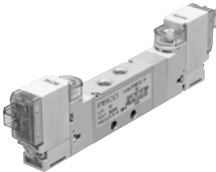

15 Series Stand-alone Unit



2-Position, 5-Port,
Single Solenoid Valve,
Connector Lead-Out Direction: Top



Model Code	CAD file name
SVB 15S-S□□-□	SVB-001

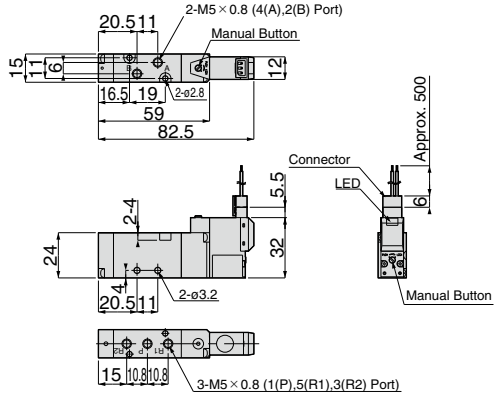
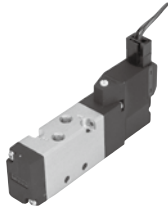

2-Position, 5-Port,
Single Solenoid Valve,
Connector Lead-Out Direction: Side



Model Code	CAD file name
SVB 15S-L□□-□	SVB-002

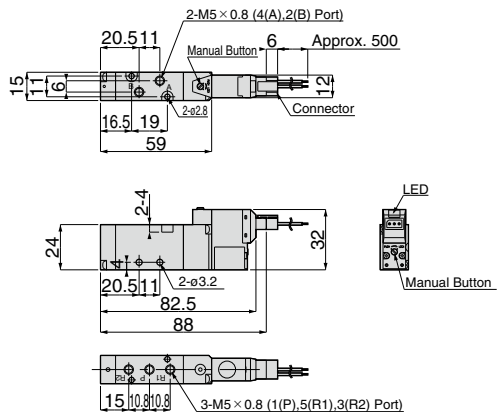
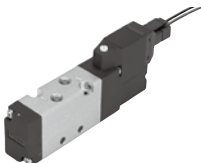

SOLENOID VALVE Series

Solenoid Valve SVB Series

SOLENOID VALVE

15 Series Stand-alone Unit



2-Position, 5-Port, Double Solenoid Valve, Connector Lead-Out Direction: Top



Model Code	CAD file name
SVB 15D-S □□ - □	SVB-001

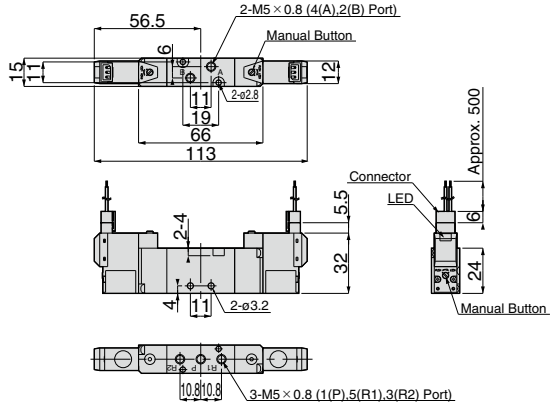
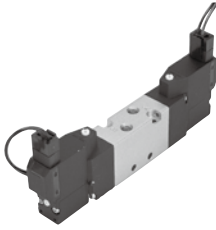

53

SVB SERIES



2-Position, 5-Port, Double Solenoid Valve, Connector Lead-Out Direction: Side



Model Code	CAD file name
SVB 15D-L □□ - □	SVB-002

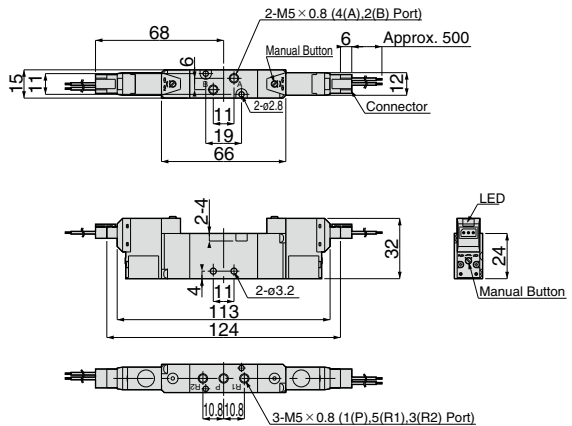
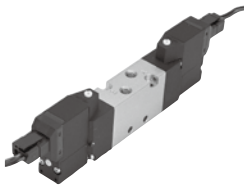

Characteristic chart page



CAD data is available at PISCO website.

SVB 15 2-Position, 5-Port Solenoid Valve

- Closed Center
 - Exhaust Center
 - Pressure Center
- Connector Lead-Out Direction: Top

Chart P.47 CAD

Model Code	CAD file name
SVB 15A-S□□-□	SVB-001
SVB 15R-S□□-□	
SVB 15P-S□□-□	

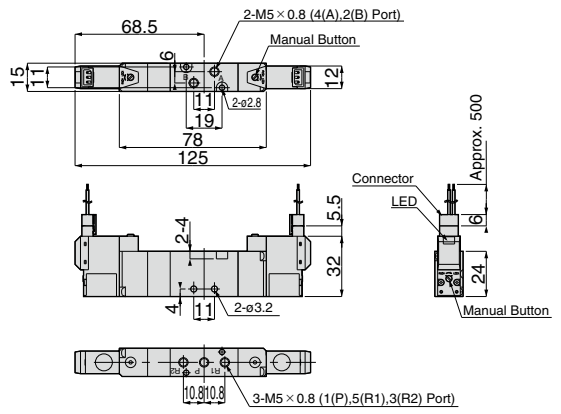
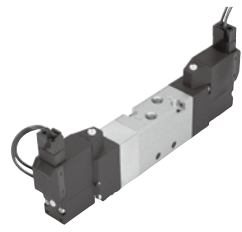

SVB 15 2-Position, 5-Port, Solenoid Valve

- Closed Center
 - Exhaust Center
 - Pressure Center
- Connector Lead-Out Direction: Side

Chart P.47 CAD

Model Code	CAD file name
SVB 15A-L□□-□	SVB-002
SVB 15R-L□□-□	
SVB 15P-L□□-□	

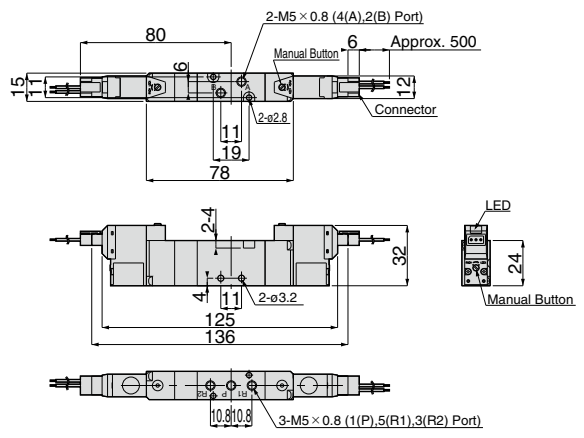
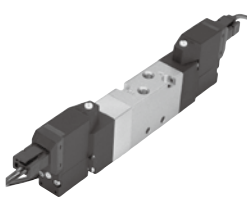

15 Series Stand-alone Unit



2-Position, 3-Port, Single Solenoid Valve

- Normally Closed
- Normally Open

Connector Lead-Out Direction: Top
(Valve for 5-port mixed mountable type)



Model Code	CAD file name
SVB 15J-S □□ - □	SVB-001
SVB 15L-S □□ - □	

* This valve is specified for 3- & 5-port mixed mountable manifold.

Valve to mount on Manifold-base

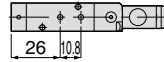
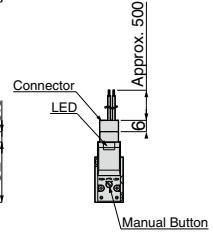
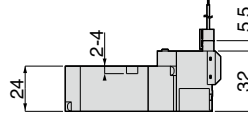
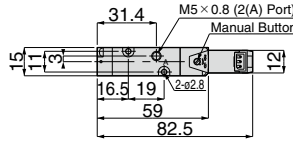
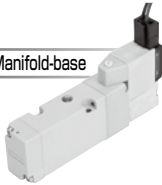

2-Position, 3-Port, Single Solenoid Valve

- Normally Closed
- Normally Open

Connector Lead-Out Direction: Side
(Valve for 5-port mixed mountable type)



Model Code	CAD file name
SVB 15J-L □□ - □	SVB-002
SVB 15L-L □□ - □	

* This valve is specified for 3- & 5-port mixed mountable manifold.

Valve to mount on Manifold-base

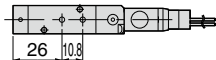
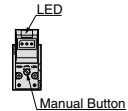
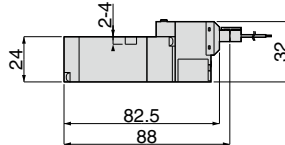
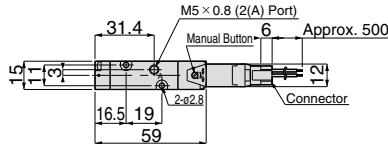
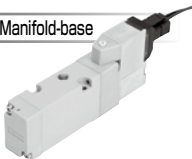

SVB 15 2-Position, 3-Port, Double Solenoid Valve
Connector Lead-Out Direction: Top
(Valve for 5-port mixed mountable type)



Model Code	CAD file name
SVB 15Y-S□□-□	SVB-001

* This valve is specified for 3- & 5-port mixed mountable manifold.

Valve to mount on Manifold-base

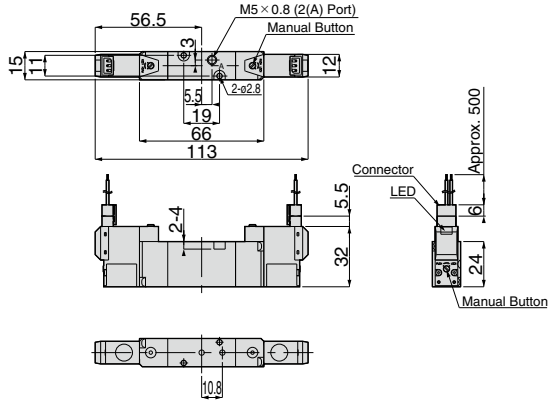

SVB 15 2-Position, 3-Port, Double Solenoid Valve
Connector Lead-Out Direction: Side
(Valve for 5-port mixed mountable type)



Model Code	CAD file name
SVB 15Y-L□□-□	SVB-002

* This valve is specified for 3- & 5-port mixed mountable manifold.

Valve to mount on Manifold-base

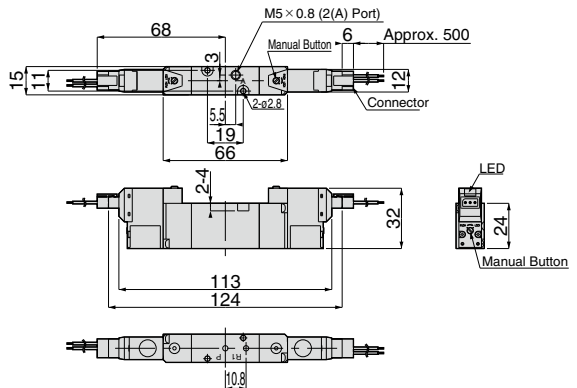
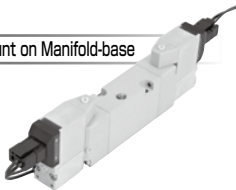

15 Series Stand-alone Unit



2-Position, 3-Port, Single Solenoid Valve

- Normally Closed
- Normally Open

Connector Lead-Out Direction: Top



Model Code	CAD file name
SVB 15M-S□□-□	SVB-003
SVB 15N-S□□-□	

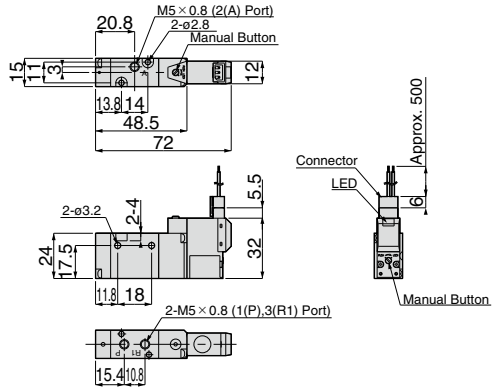

2-Position,3-Port, Single Solenoid Valve

- Normally Closed
- Normally Open

Connector Lead-Out Direction: Side



Model Code	CAD file name
SVB 15M-L□□-□	SVB-003
SVB 15N-L□□-□	

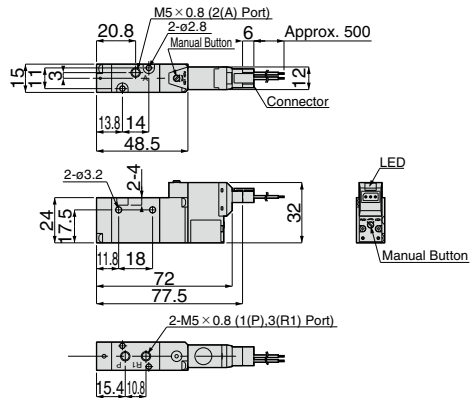



2-Position,3-Port, Double Solenoid Valve Connector Lead-Out Direction: Top



Model Code	CAD file name
SVB 15Z-S□□-□	SVB-003

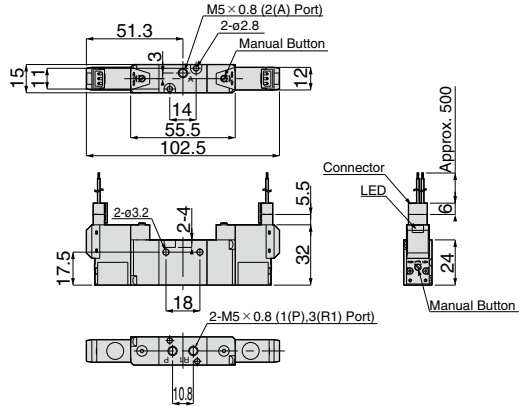

2-Position, 3-Port, Double Solenoid Valve Connector Lead-Out Direction: Side



Model Code	CAD file name
SVB 15Z-L□□-□	SVB-003

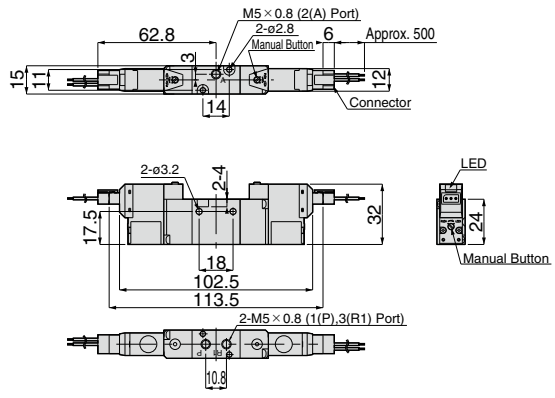

SOLENOID VALVE Series

Solenoid Valve SVB Series

SOLENOID VALVE

18 Series Stand-alone Unit



2-Position, 5-Port, Single Solenoid Valve Connector Lead-Out Direction: Top



Model Code	CAD file name
SVB 18S-S□□-□	SVB-004

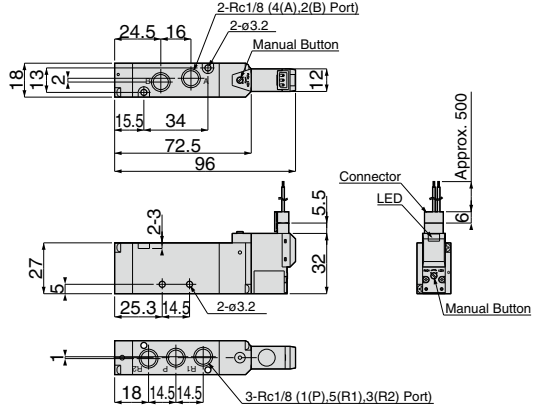
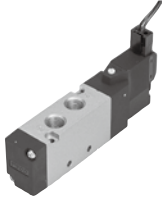

59

SVB SERIES



2-Position, 5-Port, Single Solenoid Valve Connector Lead-Out Direction: Side



Model Code	CAD file name
SVB 18S-L□□-□	SVB-005

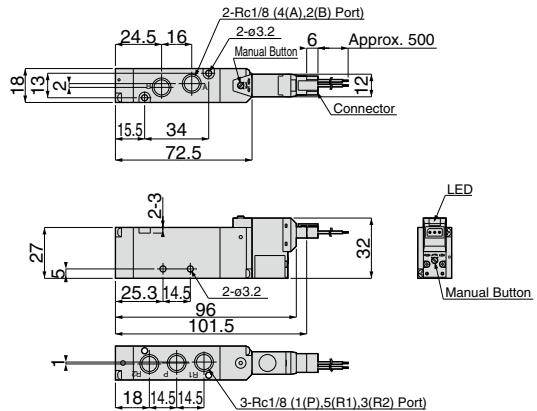

Characteristic chart page



CAD data is available at PISCO website.

SVB 18 2-Position, 5-Port, Double Solenoid Valve
Connector Lead-Out Direction: Top

Chart P.47 CAD

Model Code	CAD file name
SVB 18D-S □□ - □	SVB-004

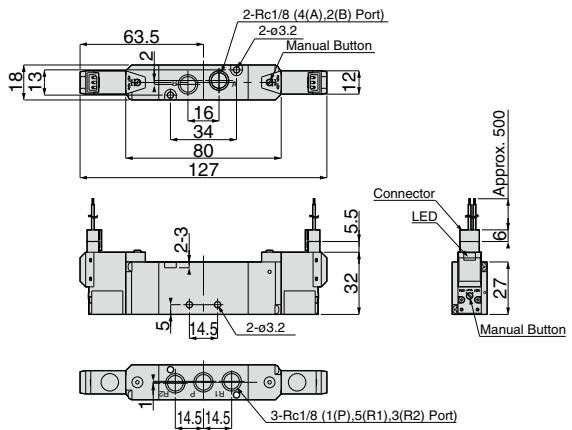

SVB 18 2-Position,5-Port, Double Solenoid Valve
Connector Lead-Out Direction: Side

Chart P.47 CAD

Model Code	CAD file name
SVB 18D-L □□ - □	SVB-005

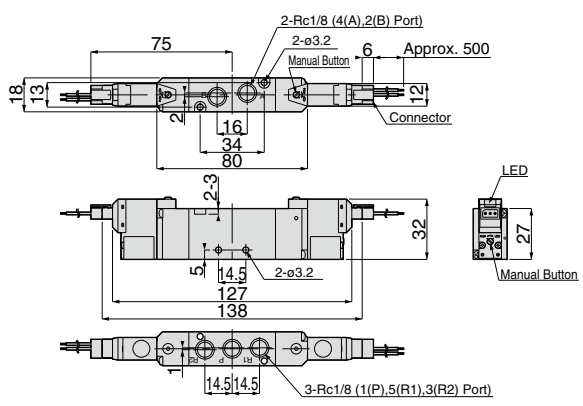
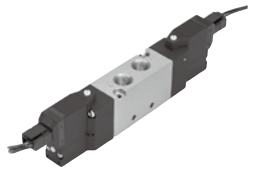

SOLENOID VALVE Series

Solenoid Valve SVB Series

SOLENOID VALVE

18 Series Stand-alone Unit



2-Position, 5-Port, Solenoid Valve

- Closed Center
- Exhaust Center
- Pressure Center

Connector Lead-Out Direction: Top



Model Code	CAD file name
SVB 18A-S □□ - □	SVB-004
SVB 18R-S □□ - □	
SVB 18P-S □□ - □	

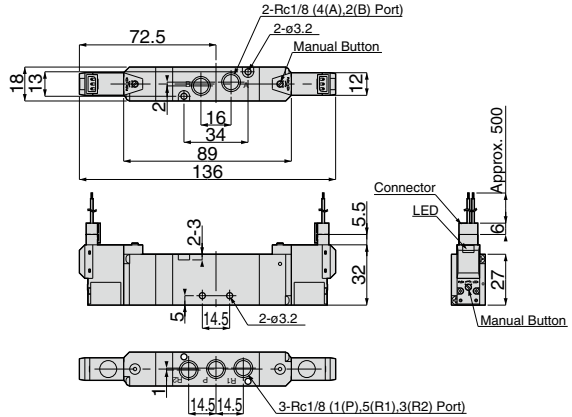

61

SVB SERIES



2-Position, 5-Port, Solenoid Valve

- Closed Center
- Exhaust Center
- Pressure Center

Connector Lead-Out Direction: Side



Model Code	CAD file name
SVB 18A-L □□ - □	SVB-005
SVB 18R-L □□ - □	
SVB 18P-L □□ - □	

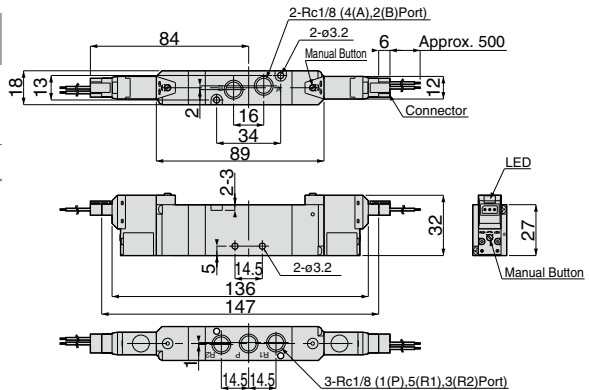
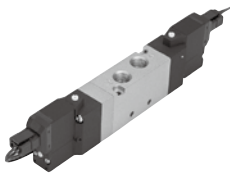

Characteristic chart page



CAD data is available at PISCO website.

SVB 18 2-Position, 3-Port, Single Solenoid Valve
 • Normally Closed
 • Normally Open
 Connector Lead-Out Direction: Top
 (Valve for 5-port mixed mountable type)



Model Code	CAD file name
SVB 18J-S□□-□	SVB-004
SVB 18L-S□□-□	

* This valve is specified for 3- & 5-port mixed mountable manifold.

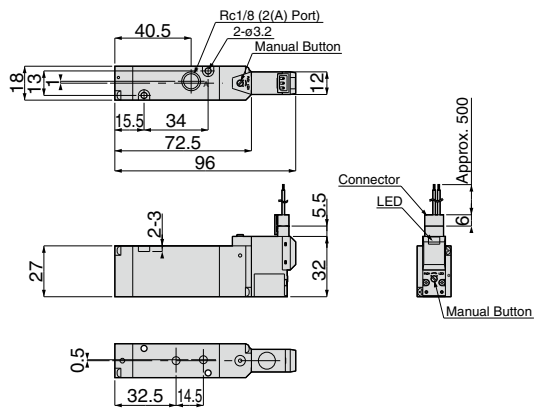
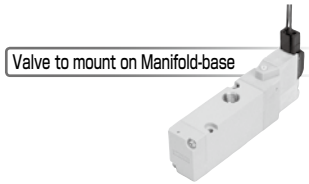

SVB 18 2-Position, 3-Port, Single Solenoid Valve
 • Normally Closed
 • Normally Open
 Connector Lead-Out Direction: Side
 (Valve for 5-port mixed mountable type)



Model Code	CAD file name
SVB 18J-L□□-□	SVB-005
SVB 18L-L□□-□	

* This valve is specified for 3- & 5-port mixed mountable manifold.

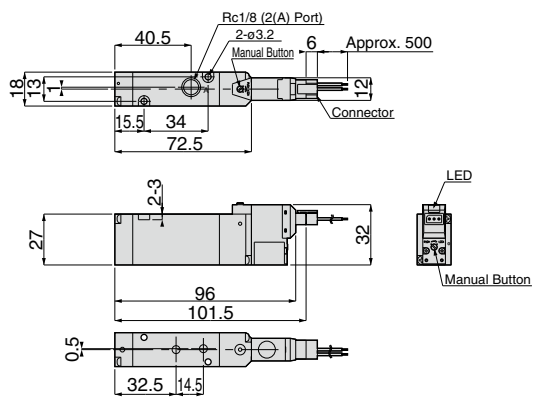

18 Series Stand-alone Unit



2-Position, 3-Port, Double Solenoid Valve Connector Lead-Out Direction: Top (Valve for 5-port mixed mountable type)



Model Code	CAD file name
SVB 18Y-S□□-□	SVB-004

* This valve is specified for 3- & 5-port mixed mountable manifold.

Valve to mount on Manifold-base

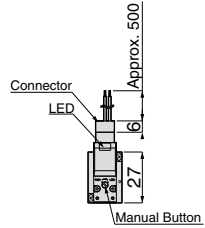
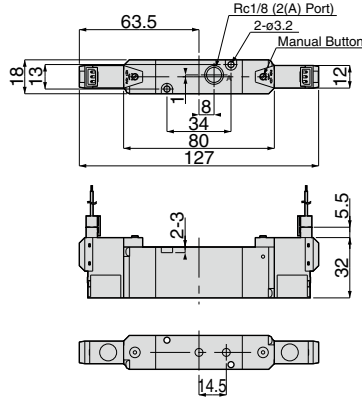

2-Position, 3-Port, Double Solenoid Valve Connector Lead-Out Direction: Side (Valve for 5-port mixed mountable type)



Model Code	CAD file name
SVB 18Y-L□□-□	SVB-005

* This valve is specified for 3- & 5-port mixed mountable manifold.

Valve to mount on Manifold-base

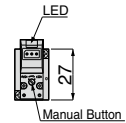
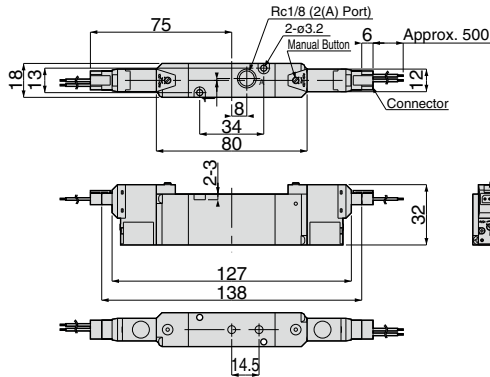



2-Position, 3-Port, Single Solenoid Valve

- Normally Closed
- Normally Open

Connector Lead-Out Direction: Top



Model Code	CAD file name
SVB 18M-S□□-□	SVB-006
SVB 18N-S□□-□	

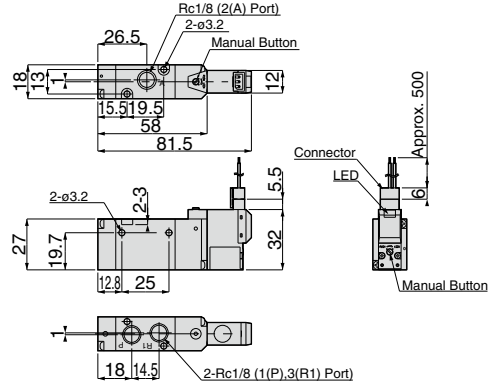

2-Position, 3-Port, Single Solenoid Valve

- Normally Closed
- Normally Open

Connector Lead-Out Direction: Side



Model Code	CAD file name
SVB 18M-L□□-□	SVB-006
SVB 18N-L□□-□	

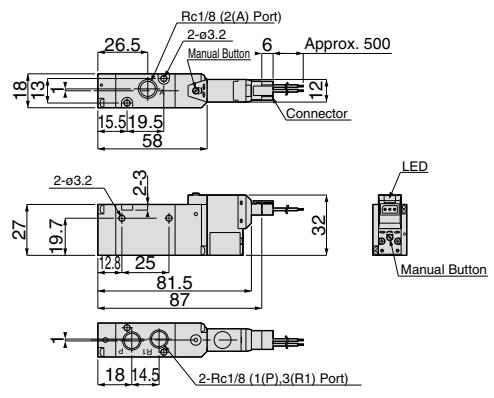

SOLENOID VALVE Series

Solenoid Valve SVB Series

SOLENOID VALVE

18 Series Stand-alone Unit



2-Position, 3-Port, Double Solenoid Valve Connector Lead-Out Direction: Top



Model Code	CAD file name
SVB 18Z-S □□ - □	SVB-006

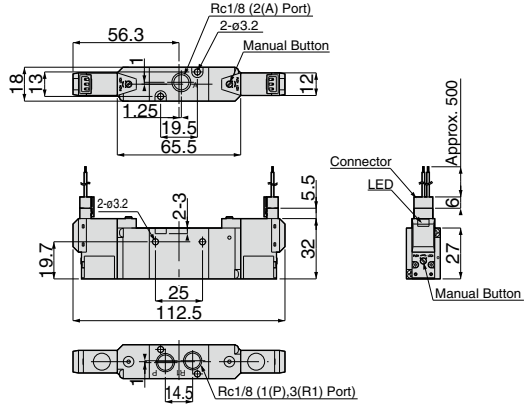

65

SVB SERIES



2-Position, 3-Port, Double Solenoid Valve Connector Lead-Out Direction: Side



Model Code	CAD file name
SVB 18Z-L □□ - □	SVB-006

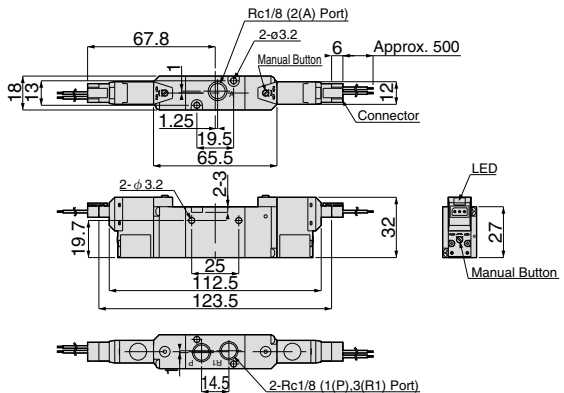

Characteristic chart page



CAD data is available at PISCO website.

■ 22 Series Stand-alone Unit



2-Position, 5-Port,
Single Solenoid Valve
Connector Lead-Out Direction: Top



Model Code	CAD file name
SVB 22S-S □□-□	SVB-007

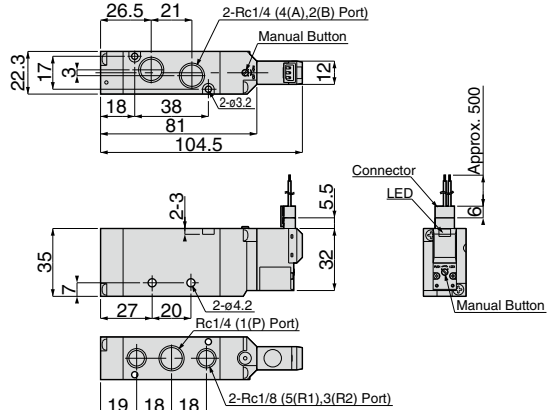

2-Position, 5-Port,
Single Solenoid Valve
Connector Lead-Out Direction: Side



Model Code	CAD file name
SVB 22S-L □□-□	SVB-008

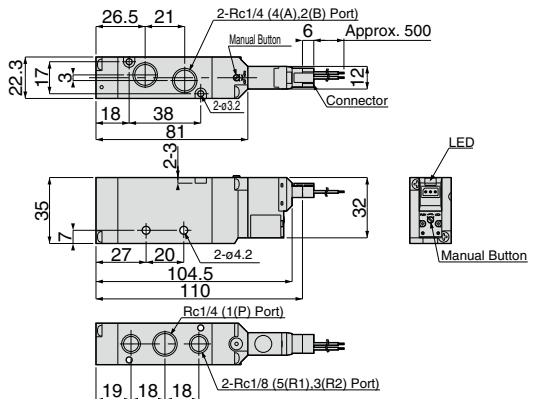

SOLENOID VALVE Series

Solenoid Valve SVB Series

SOLENOID VALVE

22 Series Stand-alone Unit



2-Position, 5-Port, Double Solenoid Valve Connector Lead-Out Direction: Top



Model Code	CAD file name
SVB 22D-S□□-□	SVB-007

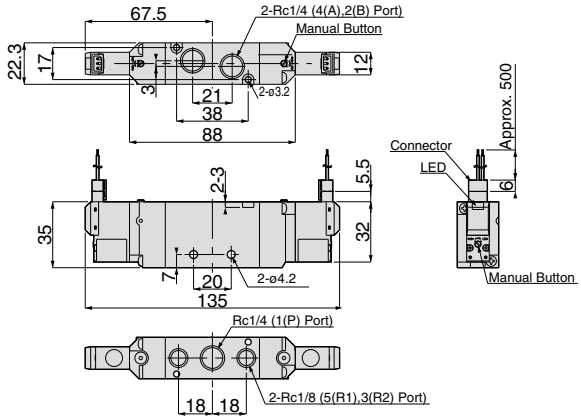
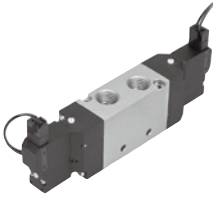

67

SVB SERIES



2-Position, 5-Port, Double Solenoid Valve Connector Lead-Out Direction: Side



Model Code	CAD file name
SVB 22D-L□□-□	SVB-008

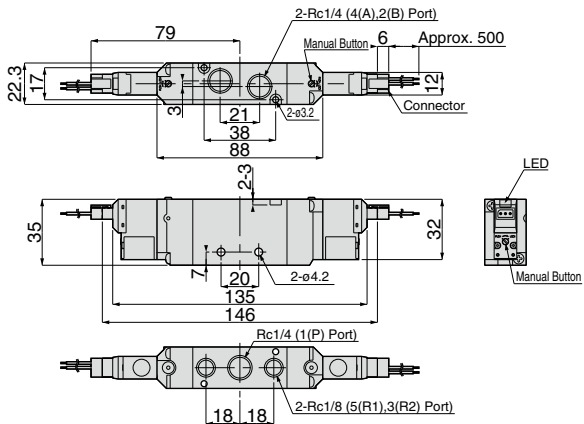
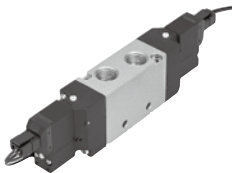

Characteristic chart page



CAD data is available at PISCO website.

SVB 22 2-Position, 5-Port, Solenoid Valve

- Closed Center
 - Exhaust Center
 - Pressure Center
- Connector Lead-Out Direction: Top



Model Code	CAD file name
SVB 22A-S□□-□	SVB-007
SVB 22R-S□□-□	
SVB 22P-S□□-□	

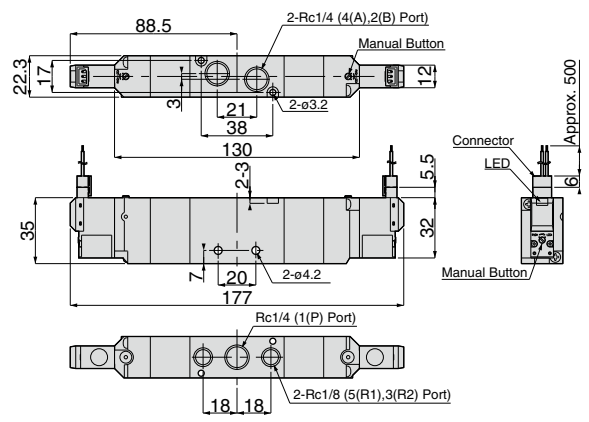
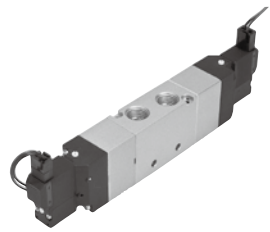

SVB 22 2-Position, 5-Port, Solenoid Valve

- Closed Center
 - Exhaust Center
 - Pressure Center
- Connector Lead-Out Direction: Side



Model Code	CAD file name
SVB 22A-L□□-□	SVB-008
SVB 22R-L□□-□	
SVB 22P-L□□-□	

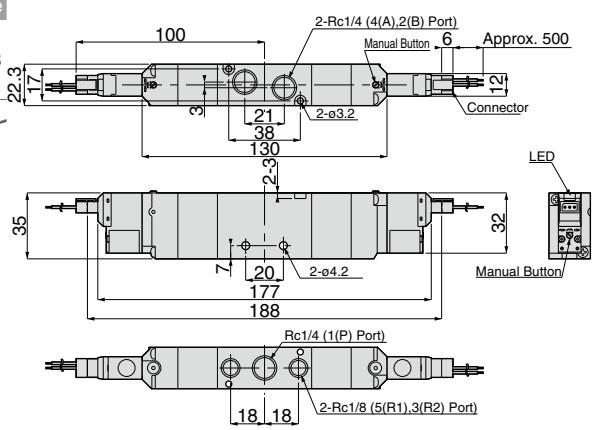
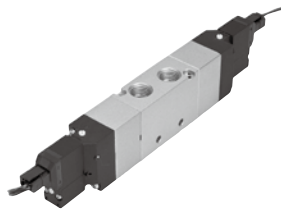

10 Series Manifold



Manifold for Direct Piping Port Type Connector Lead-Out Direction: Top

Model Code

SVB 10 □ -SW □ -□ -□ -D □

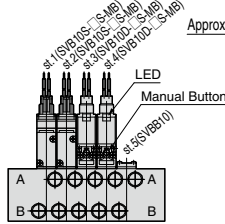
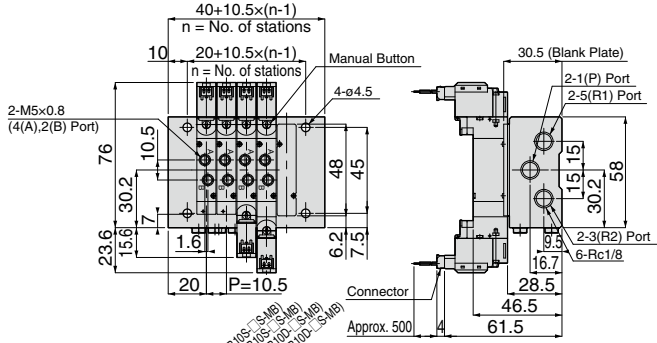
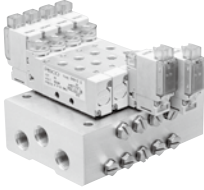

Manifold for Direct Piping Port Type Connector Lead-Out Direction: Side

Model Code

SVB 10 □ -LW □ -□ -□ -D □

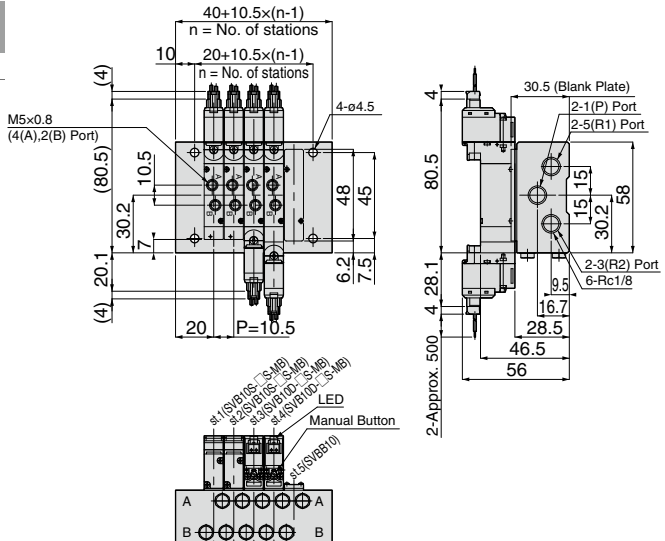
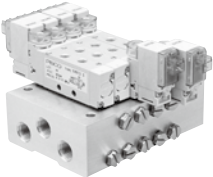

SVB 10 Manifold for Manifold-base Piping Port Connector Lead-Out Direction: Top

Model Code
SVB 10 □ -SW □ -□ -□ -B □

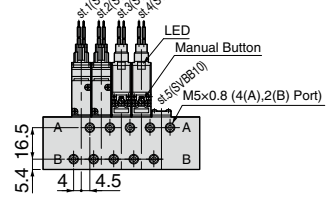
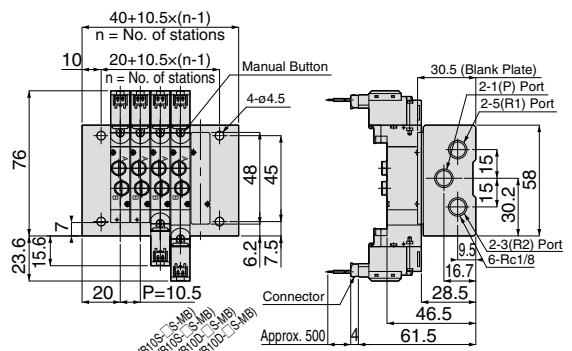
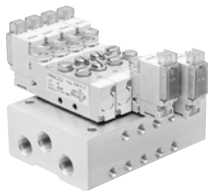

SVB 10 Manifold for Manifold-base Piping Port Connector Lead-Out Direction: Side

Model Code
SVB 10 □ -LW □ -□ -□ -B □

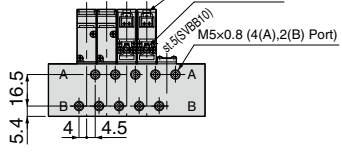
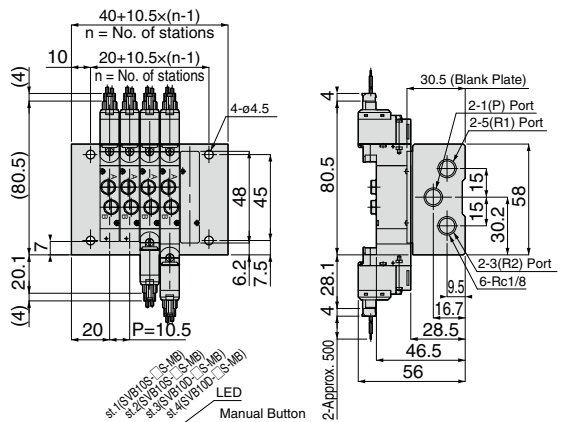
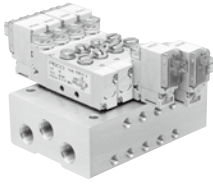

SOLENOID VALVE Series

Solenoid Valve SVB Series

SOLENOID VALVE

15 Series Manifold



Manifold For 3- & 5-port mixed mountable manifold-base Connector Lead-Out Direction: Top



Model Code	CAD file name
SVB 15 □-S□□-□-□	SVB-001

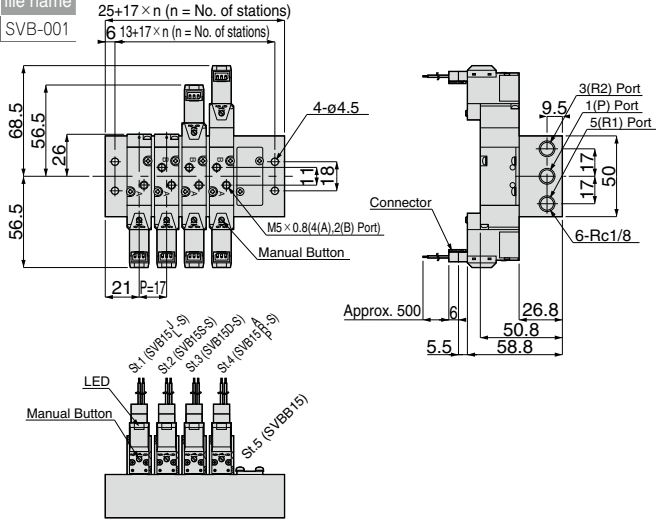
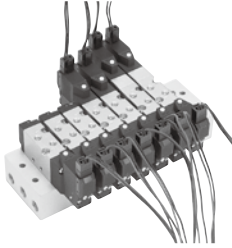

71

SVB SERIES



Manifold For 3- & 5-port mixed mountable manifold-base Connector Lead-Out Direction: Side



Model Code	CAD file name
SVB 15 □-L□□-□-□	SVB-002

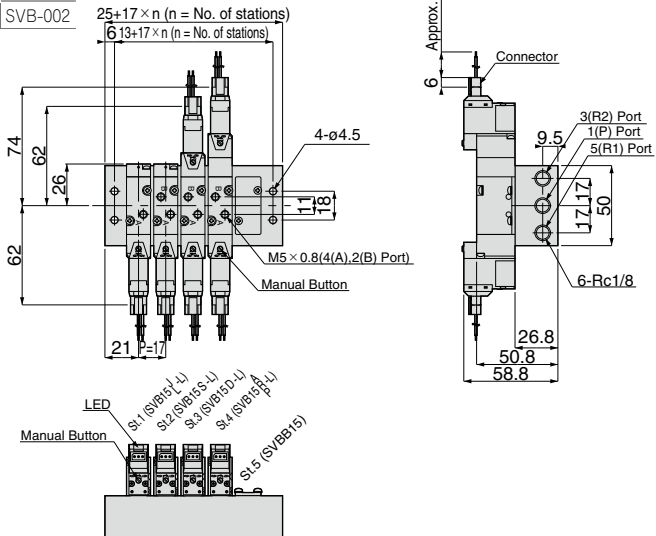
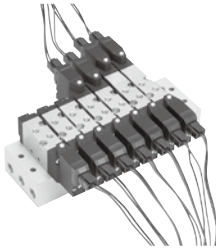

Characteristic chart page



CAD data is available at PISCO website.

SVB 15 Manifold for 3-port
Connector Lead-Out Direction: Top



Model Code	CAD file name
SVB 15 □ Y-S □ □ - □ - □	SVB-003

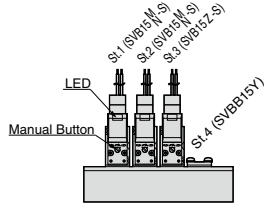
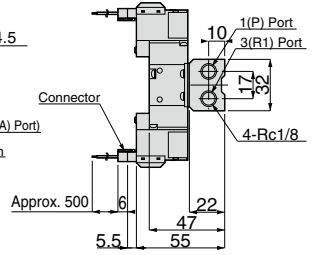
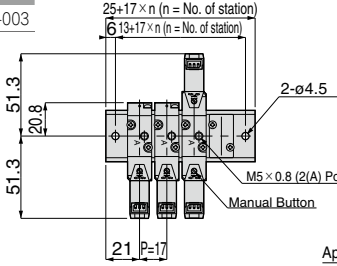
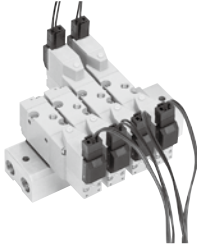

SVB 1B Manifold for 3-port
Connector Lead-Out Direction: Side



Model Code	CAD file name
SVB 15 □ Y-L □ □ - □ - □	SVB-003

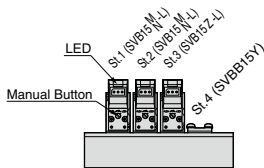
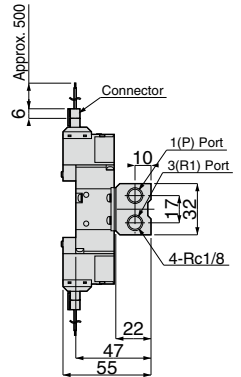
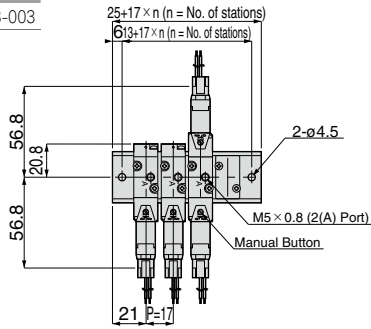
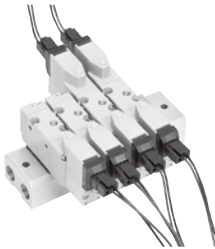

SOLENOID VALVE Series

Solenoid Valve SVB Series

SOLENOID VALVE

18 Series Manifold



Manifold For 3- & 5-port mixed mountable manifold-base Connector Lead-Out Direction: Top



Model Code	CAD file name
SVB 18 □ -S □ □ - □ - □	SVB-004

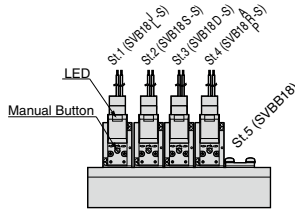
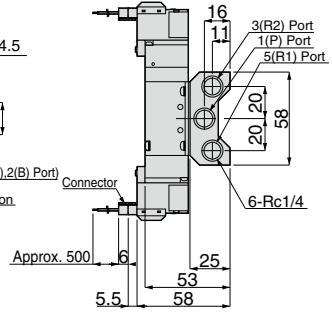
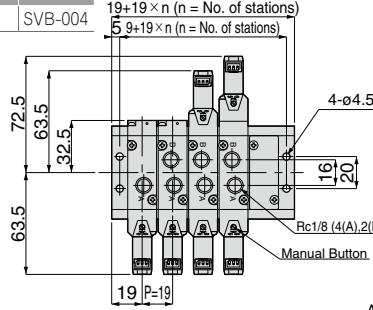
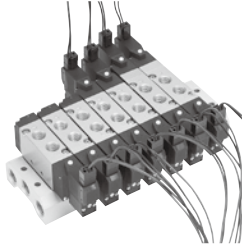

73



Manifold For 3- & 5-port mixed mountable manifold-base Connector Lead-Out Direction: Side



Model Code	CAD file name
SVB 18 □ -L □ □ - □ - □	SVB-005

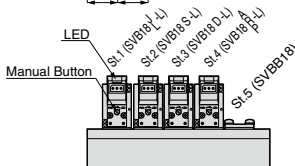
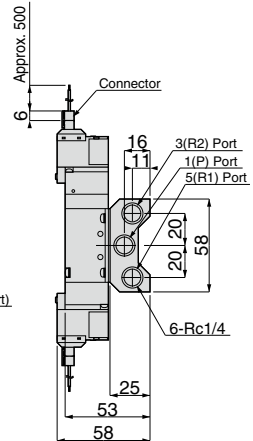
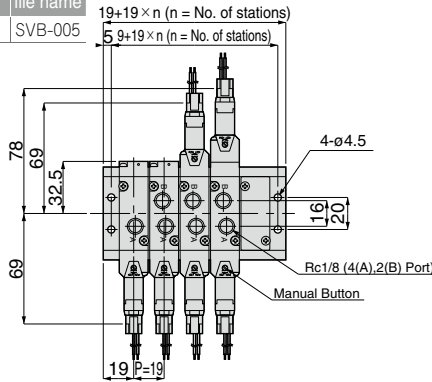
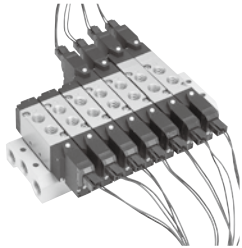

Characteristic chart page



CAD data is available at PISCO website.

SVB SERIES

SVB 18 Manifold for 3-port
Connector Lead-Out Direction: Top



Model Code	CAD file name
SVB 18 □ Y-S □ □ - □ - □	SVB-006

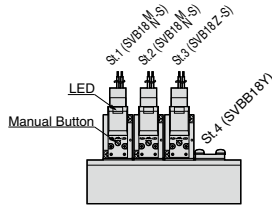
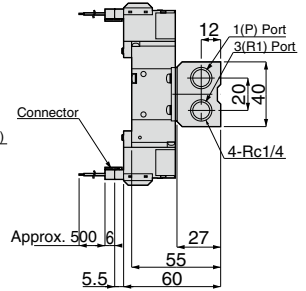
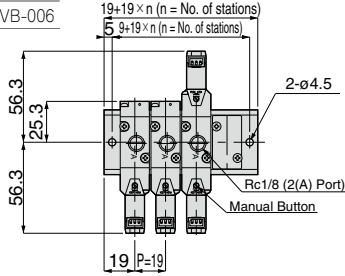

SVB 18 Manifold for 3-port
Connector Lead-Out Direction: Side



Model Code	CAD file name
SVB 18 □ Y-L □ □ - □ - □	SVB-006

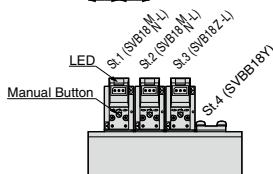
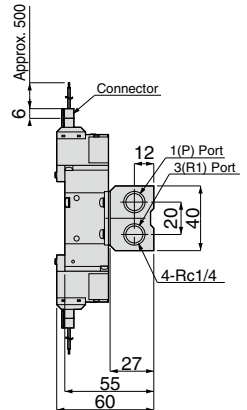
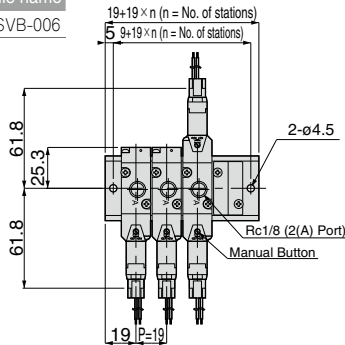
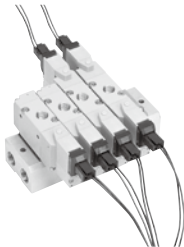

SOLENOID VALVE Series

Solenoid Valve SVB Series

SOLENOID VALVE

22 Series Manifold



Manifold For 3- & 5-port mixed mountable manifold-base Connector Lead-Out Direction: Top



Model Code	CAD file name
SVB 22 □ -S □ □ □ - □ - □	SVB-007

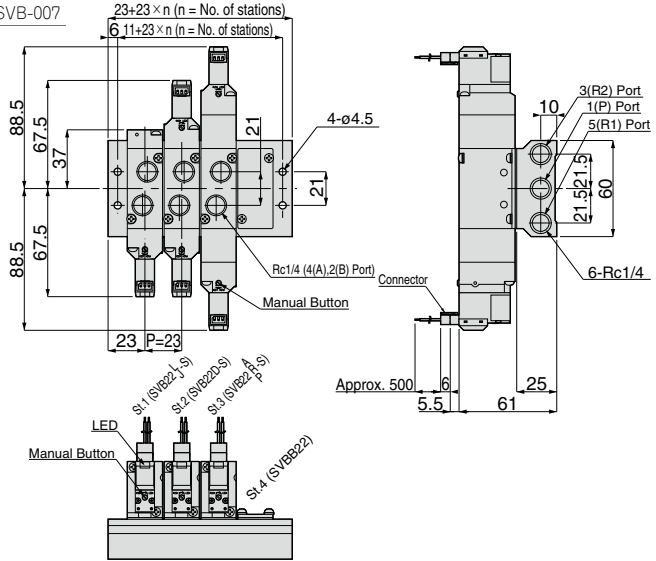
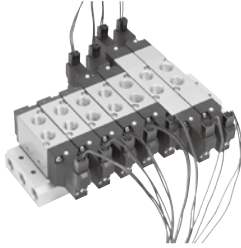

SVB 22 Manifold For 3- & 5-port mixed mountable manifold-base Connector Lead-Out Direction: Side



Model Code	CAD file name
SVB 22 □ - L □ □ - □ - □	SVB-007

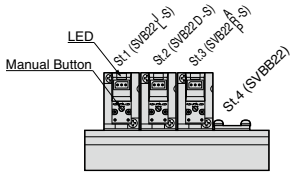
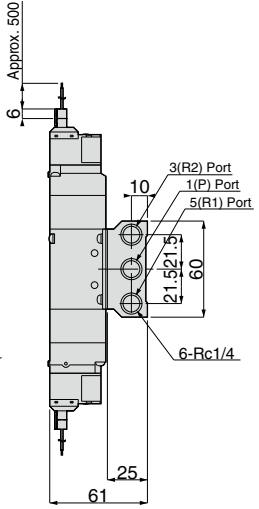
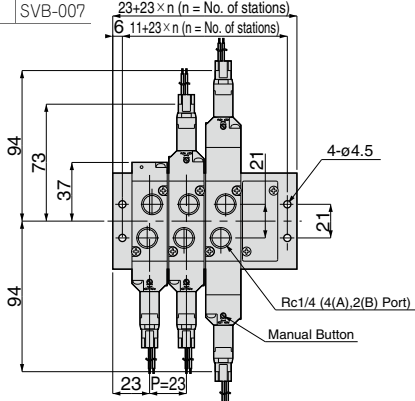
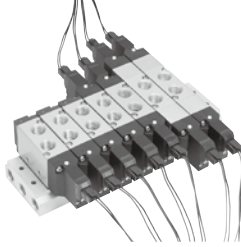

⚠ Detailed Safety Instructions

Before using PISCO products, be sure to read "Safety Instructions" and "Safety Instruction Manual" on page 17-21 and "Common Safety Instructions for Solenoid Valve Series" on page 28-29.

Warning

1. When a solenoid valve is operated under a vibration of 49m/s^2 or less, install a spool valve at a right angle to the vibrating direction.
* Refer to "4. Installation" in "Precautions for Use" on page 78.

Caution

1. When the valves are used as Valve Manifold, back pressure can cause malfunctions of the actuator (single acting cylinder, etc.) As preventional measures, provide a check valve to the exhaust port.
2. Do not use a 3-position valve for middle-position stop of the cylinder that requires accuracy. Compressiveness of air does not achieve accuracy in stop position. Also, the valve permits leakage, so that retention of stop position for long term may not be possible.
3. Do not give excessive tension or bending to the individual plug-in connector (cable). Disconnection or damage to the connector may be caused.
4. Although a surge absorber is equipped with solenoid valves with DC24V, surge can not be completely absorbed. If malfunctions by the surge is predicted, implement additional countermeasures.
5. When the manual cover of manual button is closed, manual operation and locking operation of 10 Series are not possible.

△ Safety Rules for Use

1. Air Quality

- Impurities contained in air may cause malfunctions or troubles of solenoid valves. Remove drain and dust from the supply air.
- Apply flushing to both supplying and cylinder sides when piping. Place a filter (filtering accuracy: 5μm or less) close to a solenoid valve.
- A large amount of drain, excessive lubrication and super dry air may cause malfunctions or troubles. Pay special attentions to air quality.

2. Operating Environment

- Operate solenoid valves under the following environment.
 - Within operating temp. range
 - Avoid dew condensation by temperature change
 - No water / oil drops and dust
 - No corrosive gas

3. Leakage Current

- When a solenoid valve is operated by a programmable controller, leakage current in output side shall be less than 1mA. There is a risk that the leakage current of the output can cause malfunctions.

4. Installation

- When a solenoid valve is operated under a vibrating condition, install a spool valve at a right angle to the vibrating direction. (Operate the valve under a vibration of less than 49m/s²)

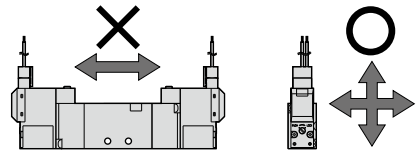

5. Lubrication

- No lubrication is recommended in principle.
- When a system needs to be lubricated, use Turbine Oil Class 1 (ISO VG 32) / free of additives. If the lubrication is stopped supplying the system in the middle of operation, malfunctions may be caused due to the scattering of initial on valves. Keep providing lubricant

6. Recommended Tightening torque for Manifold Fixing Screws

- Refer to the right table, when solenoid valves are mounted on a Manifold-base. Tightening screws with tightening torque other than the recommended range may cause unfixing or damaging valves.

Valve Series	SVB10 Series	SVB15 Series	SVB18 Series	SVB22 Series
Recommended Tightening torque	0.12~0.15N·m	0.25~0.35N·m	0.25~0.35N·m	0.3~0.5N·m

7. Electric Circuit

DC24V

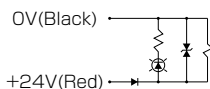

AC100V, AC110V, AC200V, AC220V

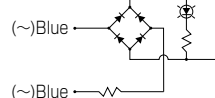

8. Attaching or detaching Individual Plug-in Connector

- The individual Plug-in Connector is attached by inserting the connector into the socket.
- In order to detach the connector, push the latch to the arrowed direction in the right figure and pull out connector.

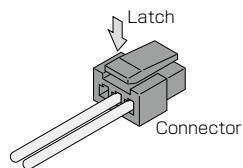

9. Manual Operation

- Switching over a valve is possible by a manual operation during supplying pilot air.
- Push a manual button with a precision screwdriver until the button stops and turn it clockwise to lock. Turn the button counterclockwise for unlocking.
(Tightening torque of the screwdriver shall be less than 0.05Nm when tightening with a precision screwdriver)
- Be sure to unlock the button before a normal operation of the valve.
- Avoid an excessive force on the button. Otherwise, damaging the product can be caused.

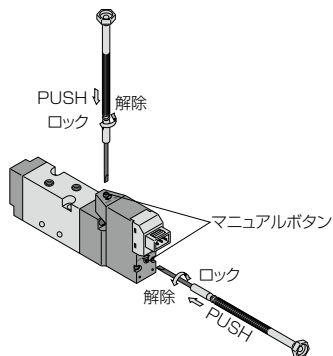

10. Tighten Fitting

- When a fitting is installed on a valve or a Manifold-base, hold the valve body or the Manifold-base. Do not hold the pilot valve. Otherwise, damaging the product can be caused.



SAFETY Instructions

This safety instructions aim to prevent personal injury and damage to properties by requiring proper use of PISCO products.

Be certain to follow ISO 4414 and JIS B 8370

ISO 4414 : Pneumatic fluid power...Recommendations for the application of equipment to transmission and control systems.

JIS B 8370 : General rules and safety requirements for systems and their components.

This safety instructions is classified into "Danger", "Warning" and "Caution" depending on the degree of danger or damages caused by improper use of PISCO products.



Danger

Hazardous conditions. It can cause death or serious personal injury.



Warning

Hazardous conditions depending on usages. Improper use of PISCO products can cause death or serious personal injury.



Caution

Hazardous conditions depending on usages. Improper use of PISCO products can cause personal injury or damages to properties.



Warning

1. Selection of pneumatic products

- ① A user who is a pneumatic system designer or has sufficient experience and technical expertise should select PISCO products.
- ② Due to wide variety of operating conditions and applications for PISCO products, carry out the analysis and evaluation on PISCO products. The pneumatic system designer is solely responsible for assuring that the user's requirements are met and that the application presents no health or safety hazards. All designers are required to fully understand the specifications of PISCO products and constitute all systems based on the latest catalog or information, considering any malfunctions.

2. Handle the pneumatic equipment with enough knowledge and experience

- ① Improper use of compressed air is dangerous. Assembly, operation and maintenance of machines using pneumatic equipment should be conducted by a person with enough knowledge and experience.

3. Do not operate machine / equipment or remove pneumatic equipment until safety is confirmed.

- ① Make sure that preventive measures against falling work-pieces or sudden movements of machine are completed before inspection or maintenance of these machine.
- ② Make sure the above preventive measures are completed. A compressed air supply and the power supply to the machine must be off, and also the compressed air in the systems must be exhausted.
- ③ Restart the machines with care after ensuring to take all preventive measures against sudden movements.

Disclaimer

1. PISCO does not take any responsibility for any incidental or indirect loss, such as production line stop, interruption of business, loss of benefits, personal injury, etc., caused by any failure on use or application of PISCO products.
2. PISCO does not take any responsibility for any loss caused by natural disasters, fires not related to PISCO products, acts by third parties, and intentional or accidental damages of PISCO products due to incorrect usage.
3. PISCO does not take any responsibility for any loss caused by improper usage of PISCO products such as exceeding the specification limit or not following the usage the published instructions and catalog allow.
4. PISCO does not take any responsibility for any loss caused by remodeling of PISCO products, or by combinational use with non-PISCO products and other software systems.
5. The damages caused by the defect of Pisco products shall be covered but limited to the full amount of the PISCO products paid by the customer.



SAFETY INSTRUCTION MANUAL

PISCO products are designed and manufactured for use in general industrial machines. Be sure to read and follow the instructions below.

Danger

1. Do not use PISCO products for the following applications.
 - ① Equipment used for maintaining / handling human life and body.
 - ② Equipment used for moving / transporting human.
 - ③ Equipment specifically used for safety purposes.

Warning

1. Do not use PISCO products under the following conditions.
 - ① Beyond the specifications or conditions stated in the catalog, or the instructions.
 - ② Under the direct sunlight or outdoors.
 - ③ Excessive vibrations and impacts.
 - ④ Exposure / adhere to corrosive gas, inflammable gas, chemicals, seawater, water and vapor. *
* Some products can be used under the condition above(④), refer to the details of specification and condition of each product.
2. Do not disassemble or modify PISCO products, which affect the performance, function, and basic structure of the product.
3. Turn off the power supply, stop the air supply to PISCO products, and make sure there is no residual air pressure in the pipes before maintenance and inspection.
4. Do not touch the release-ring of push-in fitting when there is a working pressure. The lock may be released by the physical contact, and tube may fly out or slip out.
5. Frequent switchover of compressed air may generate heat, and there is a risk of causing burn injury.
6. Avoid any load on PISCO products, such as a tensile strength, twisting and bending. Otherwise, there is a risk of causing damage to the products.
7. As for applications where threads or tubes swing / rotate, use Rotary Joints, High Rotary Joints or Multi-Circuit Rotary Block only. The other PISCO products can be damaged in these applications.
8. Use only Die Temperature Control Fitting Series, Tube Fitting Stainless SUS316 Series, Tube Fitting Stainless SUS316 Compression Fitting Series or Tube Fitting Brass Series under the condition of over 60°C (140° F) water or thermal oil. Other PISCO products can be damaged by heat and hydrolysis under the condition above.
9. As for the condition required to dissipate static electricity or provide an antistatic performance, use EG series fitting and antistatic products only, and do not use other PISCO products. There is a risk that static electricity can cause system defects or failures.
10. Use only Fittings with a characteristic of spatter-proof such as Anti-spatter or Brass series in a place where flame and weld spatter is produced. There is a risk of causing fire by sparks.
11. Turn off the power supply to PISCO products, and make sure there is no residual air pressure in the pipes and equipment before maintenance. Follow the instructions below in order to ensure safety.
 - ① Make sure the safety of all systems related to PISCO products before maintenance.
 - ② Restart of operation after maintenance shall be proceeded with care after ensuring safety of the system by preventive measures against unexpected movements of machines and devices where pneumatic equipment is used.
 - ③ Keep enough space for maintenance when designing a circuit.
12. Take safety measures such as providing a protection cover if there is a risk of causing damages or fires on machine / facilities by a fluid leakage.

⚠ Caution

1. Remove dusts or drain before piping. They may get into the peripheral machine / facilities and cause malfunction.
2. When inserting an ultra-soft tube into push-in fitting, make sure to place an Insert Ring into the tube edge. There is a risk of causing the escape of tube and a fluid leakage without using an Insert Ring.
3. The product incorporating NBR as seal rubber material has a risk of malfunction caused by ozone crack. Ozone exists in high concentrations in static elimination air, clean-room, and near the high-voltage motors, etc. As a countermeasure, material change from NBR to HNBR or FKM is necessary. Consult with PISCO for more information.
4. Special option "Oil-free" products may cause a very small amount of a fluid leakage. When a fluid medium is liquid or the products are required to be used in harsh environments, contact us for further information.
5. In case of using non-PISCO brand tubes, make sure the tolerance of the outer tube diameter is within the limits of Table 1.

● Table 1. Tube O.D. Tolerance

mm size	Nylon tube	Polyurethane tube	inch size	Nylon tube	Polyurethane tube
ø1.8mm	—	± 0.05mm	ø1/8	± 0.1mm	± 0.15mm
ø3mm	—	± 0.15mm	ø5/32	± 0.1mm	± 0.15mm
ø4mm	± 0.1mm	± 0.15mm	ø3/16	± 0.1mm	± 0.15mm
ø6mm	± 0.1mm	± 0.15mm	ø1/4	± 0.1mm	± 0.15mm
ø8mm	± 0.1mm	± 0.15mm	ø5/16	± 0.1mm	± 0.15mm
ø10mm	± 0.1mm	± 0.15mm	ø3/8	± 0.1mm	± 0.15mm
ø12mm	± 0.1mm	± 0.15mm	ø1/2	± 0.1mm	± 0.15mm
ø16mm	± 0.1mm	± 0.15mm	ø5/8	± 0.1mm	± 0.15mm

6. Instructions for Tube Insertion

- ① Make sure that the cut end surface of the tube is at right angle without a scratch on the surface and deformations.
- ② When inserting a tube, the tube needs to be inserted fully into the push-in fitting until the tubing edge touches the tube end of the fitting as shown in the figure below. Otherwise, there is a risk of leakage.

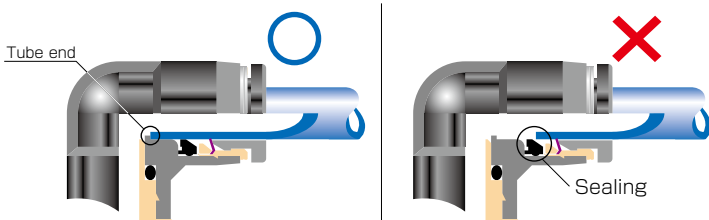

Tube is not fully inserted up to tube end.

- ③ After inserting the tube, make sure it is inserted properly and not to be disconnected by pulling it moderately.
- ※ When inserting tubes, Lock-claws may be hardly visible in the hole, observed from the front face of the release-ring. But it does not mean the tube will surely escape. Major causes of the tube escape are the followings;
- ① Shear drop of the lock-claws edge
 - ② The problem of tube diameter (usually small)
- Therefore, follow the above instructions from ① to ③, even lock-claws is hardly visible.

7. Instructions for Tube Disconnection

- ① Make sure there is no air pressure inside of the tube, before disconnecting it.
- ② Push the release-ring of the push-in fitting evenly and deeply enough to pull out the tube toward oneself. By insufficient pushing of the release-ring, the tube may not be pulled out or damaged by scratch, and tube shavings may remain inside of the fitting, which may cause the leakage later.

8. Instructions for Installing a fitting

- ① When installing a fitting, use proper tools to tighten a hexagonal-column or an inner hexagonal socket. When inserting a hex key into the inner hexagonal socket of the fitting, be careful so that the tool does not touch lock-claws. The deformation of lock-claws may result in a poor performance of systems or an escape of the tube.
- ② Refer to Table 2 which shows the recommended tightening torque. Do not exceed these limits to tighten a thread. Excessive tightening may break the thread part or deform the gasket and cause a fluid leakage. Tightening thread with tightening torque lower than these limits may cause a loosened thread or a fluid leakage.
- ③ Adjust the tube direction while tightening thread within these limits, since some PISCO products are not rotatable after the installation.

● Table 2: Recommended tightening torque / Sealock color / Gasket materials

Thread type	Thread size	Tightening torque	Sealock color	Gasket materials
Metric thread	M3 × 0.5	0.7N·m	—	SUS304 NBR
	M5 × 0.8	1.0 ~ 1.5N·m		
	M6 × 1	2 ~ 2.7N·m		
	M3 × 0.5	0.7N·m		POM
	M5 × 0.8	1 ~ 1.5N·m		
	M6 × 0.75	0.8 ~ 1N·m		
Taper pipe thread	M8 × 0.75	1 ~ 2N·m	White	—
	R1/8	4.5 ~ 6.5N·m		
	R1/4	7 ~ 9N·m		
	R3/8	12.5 ~ 14.5N·m		
Unified thread	R1/2	20 ~ 22N·m	—	SUS304, NBR
	No.10-32UNF	1.0 ~ 1.5N·m		
National pipe thread taper	1/16-27NPT	4.5 ~ 6.5N·m	White	—
	1/8-27NPT	4.5 ~ 6.5N·m		
	1/4-18NPT	7 ~ 9N·m		
	3/8-18NPT	12.5 ~ 14.5N·m		
	1/2-14NPT	20 ~ 22N·m		

※ These values may differ for some products. Refer to each specification as well.

9. Instructions for removing a fitting

- ① When removing a fitting, use proper tools to loosen a hexagonal-column or an inner hex bolt.
- ② Remove the sealant stuck on the mating equipment. The remained sealant may get into the peripheral equipment and cause malfunctions.

10. Arrange piping avoiding any load on fittings and tubes such as twist, tensile, moment load, shaking and physical impact. These may cause damages to fittings, tube deformations, bursting and the escape of tubes.



Common Safety Instructions for Solenoid Valve Series

Before selecting or using PISCO products, read the following instructions. Read the detailed instructions for individual series.

⚠ Warning

1. When piping, pipe flushing is required for pipes at both air supply and actuator sides. A filter (filtering accuracy should be $5\mu\text{m}$ or less) should be located close to a solenoid valve on the upstream side. Drain or dust can cause malfunctions.
2. Do not supply compressed air or dry air more than necessary. Deterioration of seal rubber or oil can cause malfunctions.
3. Do not use a solenoid valve in the location where it is exposed to water, oil and dust falling. Using in such circumstance may cause malfunctions or damages, since the valve is neither drip- nor dust- proof. (Protection Structure: IP30)
4. Solenoid valve is not explosive-proof. Do not use a solenoid valve in the location it is exposed to inflammable and explosive gasses or liquid. Using in such circumstance can cause a fire or explosion.
5. Do not use a solenoid valve in the location where it is exposed to corrosive gas. Using in such circumstance can cause trouble.
6. Do not use a solenoid valve in the location where it is exposed excessive vibrating or shock. Using in such circumstance can cause malfunctions or trouble.
7. Make sure a leakage current is 1 mA or less before starting the valve. A leakage current more than 1 mA can cause malfunctions.
8. The coil in a valve generates heat by the following (1) to (3) conditions. Heating can impair the product life or cause problems in operation. Heating can also cause getting burnt or damaging peripheral machines. Contact us when energization is necessary under the following conditions:
 - (1) The power is continuously on for more than 2 hours.
 - (2) High-cycle operation
 - (3) The total operation time per day is longer than non-operation time even the generator is operated intermittently.

 **Caution**

1. A solenoid valve allows air leakage. Do not use the valve for applications which requires air tightness.
2. Do not use a solenoid valve for a large air-blow. A drop of inner pressure can cause the internally piloted-valve structure malfunctions.
3. When a solenoid valve is switched over by a manual operation, connected actuators start operation. Confirm the safety before the system is operated.
4. Make sure to turn off the power supply and wire colors before wiring.
5. Solenoid valves work without lubrication. When lubrication is necessary, use Turbine Oil Class 1 (ISO VG 32). If lubrication is stopped in the middle of the operation, it can cause malfunctions due to the loss of initial lubricant on valves. Keep providing lubricant.
6. Make sure each port by a marking on a solenoid valve body when piping.
7. Turn off the power and air supply and make sure the residual pressure becomes zero before maintenance. It should be noted that the residual pressure exists between a solenoid valve and an actuator in Three-Position Closed Center type.
8. Clogged element of a manifold with silencer increases the exhaust resistance. It can also cause impairing the performance in a whole pneumatic system. Carry out the maintenance periodically.
9. Thoroughly read and understand instructions and precautions in this catalog before replacing a silencer element.