

PHE GÀI TRỤC TIÊU CHUẨN DIN 471

Vật liệu	EX10R	THÉP LÒ XO 65 Mn (Độ Cứng 44-53 HRC)
	EX30R	Inox SUS420 (Độ Cứng 36-44 HRC)

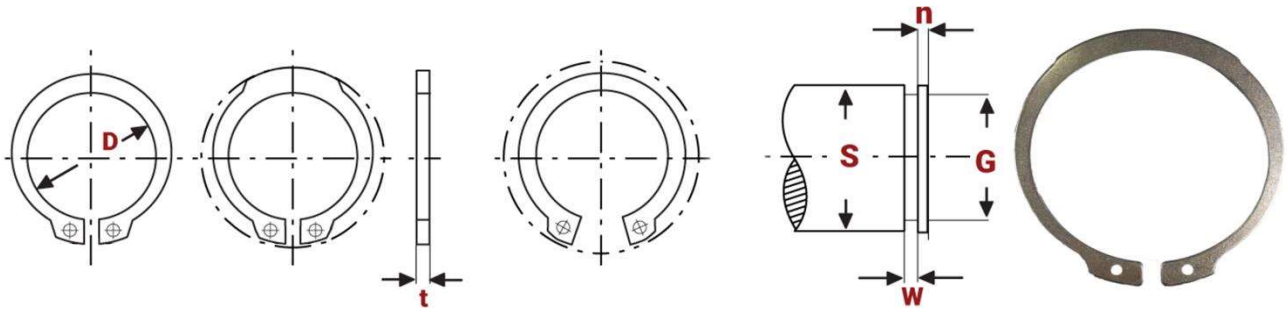

Mã hàng		Đường kính S (mm)	Kích thước sản phẩm				Kích thước rãnh trên trục		
Thép	Inox 420		D (mm)		t (mm)		G (mm)	W (mm)	n (Min)
			Min	Max	Min	Max			
EX10R3-04	-	3	2.55	2.74	0.35	0.4	2.8	0.5	0.3
EX10R4-04	EX30R4-04	4	3.55	3.74			3.8		
EX10R5-06	EX30R5-06	5	4.55	4.74	0.55	0.6	4.8	0.7	
EX10R6-07	EX30R6-07	6	5.45	5.64	0.65	0.7	5.7	0.8	0.5
EX10R7-08	EX30R7-08	7	6.32	6.56	0.75	0.8	6.7	0.9	
EX10R8-08	EX30R8-08	8	7.22	7.46			7.6		
EX10R9-10	EX30R9-10	9	8.22	8.46	0.94	1	8.6	1.1	0.6
EX10R10-10	EX30R10-10	10	8.94	9.4			9.6		0.8
EX10R11-10	EX30R11-10	11	9.84	10.3			10.5		0.9
EX10R12-10	EX30R12-10	12	10.64	11.1			11.5		1.1
EX10R13-10	EX30R13-10	13	11.54	12			12.4		0.9
EX10R14-10	EX30R14-10	14	12.54	13			13.4		1.2
EX10R15-10	EX30R15-10	15	13.44	13.9			14.3		1.1
EX10R16-10	EX30R16-10	16	14.34	14.8			15.2		1.2
EX10R17-10	EX30R17-10	17	15.34	15.8	1.14	1.2	16.2	1.3	
EX10R18-12	EX30R18-12	18	16.14	16.6			17		1.5
EX10R19-12	EX30R19-12	19	17.14	17.6			18		
EX10R20-12	EX30R20-12	20	18.08	18.63			19		1.7
EX10R21-12	EX30R21-12	21	19.08	19.63			20		
EX10R22-12	EX30R22-12	22	20.08	20.63			21		1.5
EX10R23-12	EX30R23-12	23	-	21.5			22		
EX10R24-12	EX30R24-12	24	21.78	22.41			22.9		1.7
EX10R25-12	EX30R25-12	25	22.78	23.41	23.9				
EX10R26-12	EX30R26-12	26	23.78	24.41	24.9	1.5			
EX10R27-12	EX30R27-12	27	-	24.9	25.6				
EX10R28-15	EX30R28-15	28	25.48	26.11	1.44	1.5	26.6	1.6	2.1
EX10R29-15	EX30R29-15	29	26.48	27.11			27.6		
EX10R30-15	EX30R30-15	30	27.48	28.11	-	1.5	28.6	1.6	2.6
EX10R31-15	EX30R31-15	31	-	28.6			29.3		
EX10R32-15	EX30R32-15	32	29.18	29.6	1.93	1.5	30.3	1.6	

PHE GÀI TRỤC TIÊU CHUẨN DIN 471

Vật liệu	EX10R	THÉP LÒ XO 65 Mn (Độ Cứng 44-53 HRC)
	EX30R	THÉP KHÔNG GỈ (Độ Cứng 36-44 HRC)

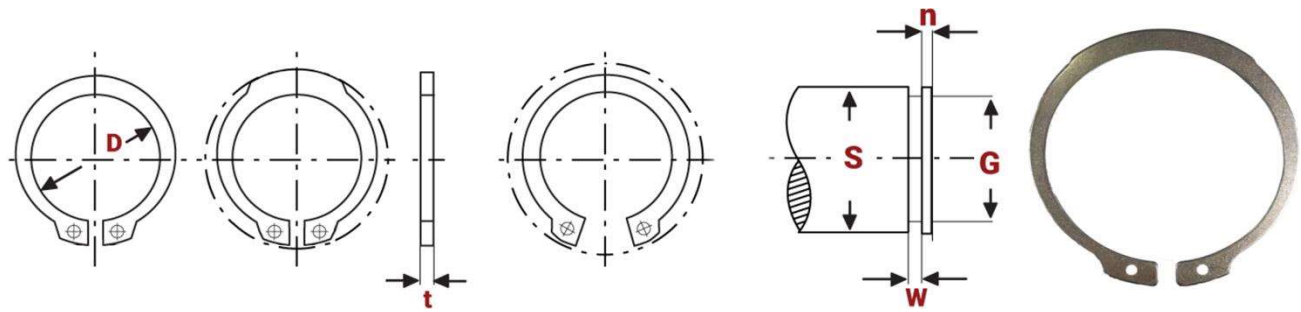

Mã hàng		Đường kính S (mm)	Kích thước sản phẩm				Kích thước rãnh trên trục		
Thép	Inox 420		D (mm)		t (mm)		G (mm)	W (mm)	n (Min)
			Min	Max	Min	Max			
EX10R33-15	EX30R33-15	33	-	30.5	-	1.5	31.3	1.6	1.6
EX10R34-15	EX30R34-15	34	31	31.5	2.43		32.2		
EX10R35-15	EX30R35-15	35	31.7	32.2			33		
EX10R36-175	EX30R36-175	36	-	33.2		3	34		
EX10R37-175	EX30R37-175	37	-	34.2			35		
EX10R38-175	EX30R38-175	38	34.7	35.2			36		
EX10R39-175	EX30R39-175	39	-	36			37		
EX10R40-175	EX30R40-175	40	35.6	36.5		3.8	37.5		
EX10R41-175	EX30R41-175	41	-	37.5			38.5		
EX10R42-175	EX30R42-175	42	37.6	38.5			1.75	39.5	
EX10R43-175	EX30R43-175	43	-	39.5				40.5	
EX10R44-175	EX30R44-175	44	-	40.5	41.5				
EX10R45-175	EX30R45-175	45	40.6	41.5	42.5				
EX10R46-175	EX30R46-175	46	-	42.5	43.5				
EX10R47-175	EX30R47-175	47	-	43.5	44.5				
EX10R48-175	EX30R48-175	48	43.6	44.5	45.5				
EX10R50-20	EX30R50-20	50	44.9	45.8	2.92	47	2.15	4.5	
EX10R51-20	EX30R51-20	51	-	46.8		2			48
EX10R52-20	EX30R52-20	52	46.9	47.8					49
EX10R54-20	EX30R54-20	54	-	49.8					51
EX10R55-20	EX30R55-20	55	49.7	50.8					52
EX10R56-20	EX30R56-20	56	-	51.8		53			
EX10R57-20	EX30R57-20	57	-	52.8		54			
EX10R58-20	EX30R58-20	58	52.7	53.8		55			
EX10R60-20	EX30R60-20	60	54.7	55.8		57			
EX10R62-20	EX30R62-20	62	-	57.8		-			59
EX10R63-20	EX30R63-20	63	-	58.8	-	60			
EX10R65-25	EX30R65-25	65	61.26	60.8	3.9	2.5	62	2.65	
EX10R67-25	EX30R67-25	67	-	62.5			64		
EX10R68-25	EX30R68-25	68	-	63.5			65		

PHE GÀ TRỤC TIÊU CHUẨN DIN 471

Vật liệu	EX10R	THÉP LÒ XO 65 Mn (Độ Cứng 44-53 HRC)
	EX30R	THÉP KHÔNG GỈ (Độ Cứng 36-44 HRC)

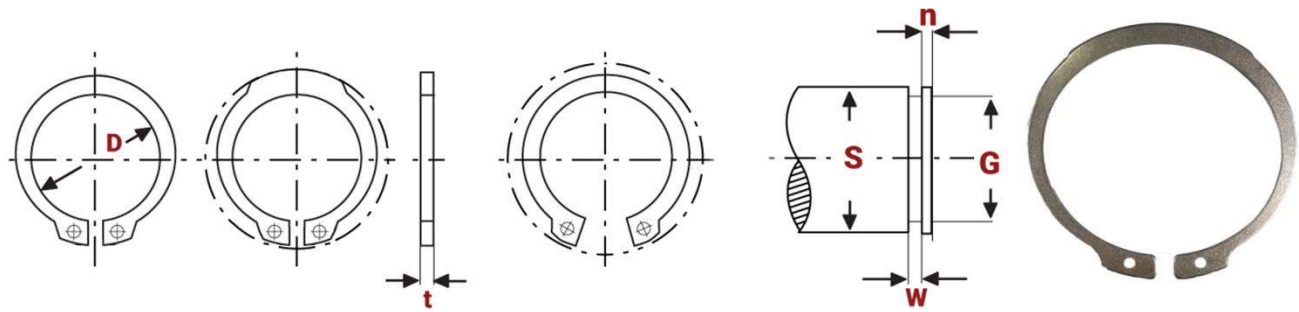

Mã hàng		Đường kính S (mm)	Kích thước sản phẩm				Kích thước rãnh trên trục		
Thép	Inox 420		D (mm)		t (mm)		G (mm)	W (mm)	n (Min)
			Min	Max	Min	Max			
EX10R70-25	EX30R70-25	70	65.96	65.5	2.5	67	2.65	4.5	
EX10R72-25	EX30R72-25	72	-	67.5		69			
EX10R75-25	EX30R75-25	75	70.96	70.5		72			
EX10R77-25	EX30R77-25	77	-	72.5		74			
EX10R78-25	EX30R78-25	78	-	73.5		75			
EX10R80-25	EX30R80-25	80	74.96	74.5		76.5			
EX10R82-25	EX30R82-25	82	-	76.5	78.5	3.15	5.3		
EX10R85-30	EX30R85-30	85	79.96	79.5	81.5				
EX10R87-30	EX30R87-30	87	-	81.5	83.5				
EX10R88-30	EX30R88-30	88	-	82.5	84.5				
EX10R90-30	EX30R90-30	90	85.04	84.5	86.5				
EX10R92-30	EX30R92-30	92	-	86.5	88.5				
EX10R95-30	EX30R95-30	95	-	89.5	91.5	3.9	3	5.3	
EX10R97-30	EX30R97-30	97	-	91.5	93.5				
EX10R98-30	EX30R98-30	98	-	92.5	93.5				
EX10R100-30	EX30R100-30	100	95.04	94.5	96.5				
EX10R102-40	EX30R102-40	102	-	95	98				
EX10R105-40	EX30R105-40	105	-	98	101				
EX10R107-40	EX30R107-40	107	-	100	103	4	4.15	6	
EX10R108-40	EX30R108-40	108	-	101	103				
EX10R110-40	EX30R110-40	110	-	103	106				