

# NYLON-INSULATED CORD END TERMINALS (E SERIES)

**MAXIMUM ELECTRIC CURRENT:**

A.W.G.	26	24	22	20	18
AMP.	5.5	7	9	12	17

**MAXIMUM ELECTRICAL RATING: 105°C 600 VOLTS MAX.**

**CONNECTOR MATERIAL: COPPER TUBE.**

**INSULATION MATERIAL: NYLON**

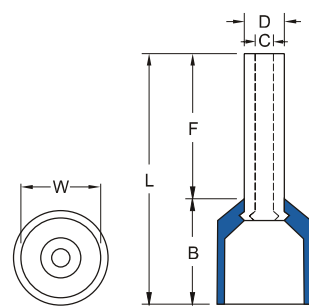

WIRE RANGE A.W.G. mm <sup>2</sup>	ITEM NO.	DIMENSION <small>inch mm</small>						FRENCH COLOR	GERMAN COLOR	DIN COLOR	CRIMPING TOOL	
		F	L	W	B	D	C					
24 A.W.G. 0.25 mm <sup>2</sup>	E0205	.197 5.0	.370 9.4	.075 1.9	.173 4.4	.043 1.1	.031 0.8	VIOLET	LIGHT BLUE		K.S. MODEL <b>LY8-060</b> WITH DIE INDEX NO:0.25-0.75	
	E0206	.236 6.0	.409 10.4									
	E0208	.315 8.0	.488 12.4									
22 A.W.G. 0.34 mm <sup>2</sup>	E0305	.197 5.0	.370 9.4	.075 1.9	.173 4.4	.043 1.1	.031 0.8	PINK	TURQUOISE			
	E0306	.236 6.0	.409 10.4									
	E0308	.315 8.0	.488 12.4									
	E0309	.354 9.0	.528 13.4									
20 A.W.G. 0.5 mm <sup>2</sup>	E0505	.197 5.0	.433 11.0	.102 2.6	.236 6.0	.051 1.3	.039 1.0	WHITE	ORANGE	WHITE		K.S. MODEL <b>KST2000L</b> WITH DIE INDEX NO:0.5 OR K.S. MODEL <b>LY8-060</b> WITH DIE INDEX NO:0.25-0.75
	E0506	.236 6.0	.472 12.0									
	E0508	.315 8.0	.551 14.0									
	E0509	.354 9.0	.591 15.0									
	E0510	.394 10.0	.630 16.0									
	E0512	.472 12.0	.709 18.0									
18 A.W.G. 0.75 mm <sup>2</sup>	E7505	.197 5.0	.445 11.3	.110 2.8	.248 6.3	.059 1.5	.047 1.2	BLUE	WHITE	GREY	K.S. MODEL <b>KST2000L</b> WITH DIE INDEX NO:0.75 OR K.S. MODEL <b>LY8-060</b> WITH DIE INDEX NO:0.25-0.75	
	E7506	.236 6.0	.484 12.3									
	E7508	.315 8.0	.563 14.3									
	E7508-L	.315 8.0	.571 14.5	.118 3.0	.256 6.5							
	E7510	.394 10.0	.642 16.3	.110 2.8	.248 6.3							
	E7510-L	.394 10.0	.650 16.5	.118 3.0	.256 6.5							
	E7512	.472 12.0	.720 18.3	.110 2.8	.248 6.3							
	E7512-L	.472 12.0	.728 18.5	.118 3.0	.256 6.5							
	E7518	.709 18.0	.957 24.3	.110 2.8	.248 6.3							
	E7518-L	.709 18.0	.965 24.5	.118 3.0	.256 6.5							
18 A.W.G. 1.0 mm <sup>2</sup>	E1006	.236 6.0	.472 12.0	.118 3.0	.248 6.3	.067 1.7	.055 1.4	RED	YELLOW	RED	K.S. MODEL <b>KST2000L</b> WITH DIE INDEX NO:1 OR K.S. MODEL <b>LY8-060</b> WITH DIE INDEX NO:1-1.5	
	E1006-L	.236 6.0	.492 12.5	.650 3.3								
	E1008	.315 8.0	.551 14.0	.118 3.0								.248 6.3
	E1008-L	.315 8.0	.571 14.5	.130 3.3								.256 6.5
	E1010	.394 10.0	.630 16.0	.118 3.0								.248 6.3
	E1010-L	.394 10.0	.650 16.5	.650 3.3								.256 6.5
E1012	.472 12.0	.709 18.0	.118 3.0	.248 6.3								