

# Miniature and Small Size Ball Bearings

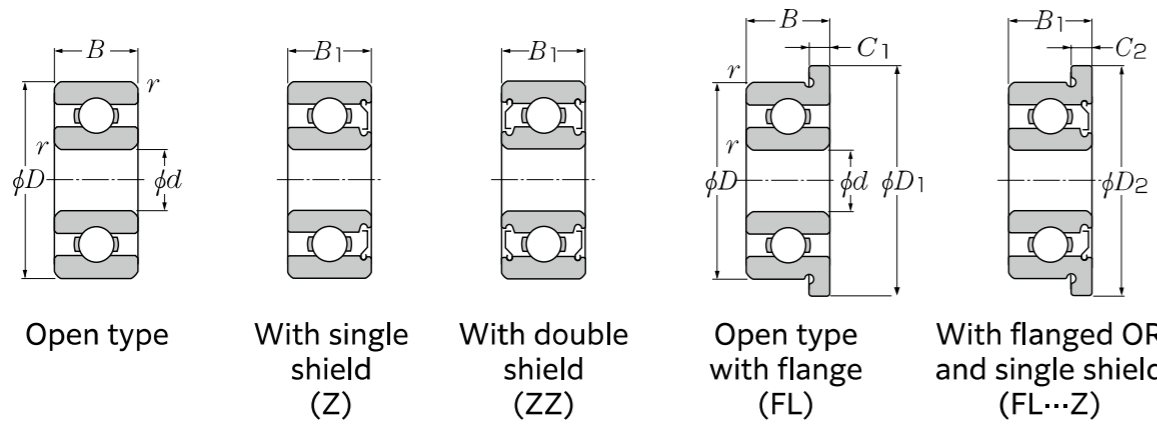

## Metric series



d 1.5 ~ 5mm

d	Boundary dimensions mm								Basic load rating		Fatigue load limit N C <sub>u</sub>	Factor f <sub>0</sub>	Allowable speed min <sup>-1</sup>	
	D	B	B <sub>1</sub>	D <sub>1</sub>	D <sub>2</sub>	C <sub>1</sub>	C <sub>2</sub>	r <sub>s min</sub> <sup>1)</sup>	C <sub>r</sub>	C <sub>0r</sub>			Grease lubrication	Oil lubrication
1.5	4	1.2	2	5	5	0.4	0.6	0.15	113	29.0	0.775	13.6	88 000	100 000
	5	2	2.6	6.5	6.5	0.6	0.8	0.15	189	51.0	1.35	13.3	79 000	93 000
	6	2.5	3	7.5	7.5	0.6	0.8	0.15	305	86.0	2.28	12.3	71 000	84 000
2	4	1.2	—	—	—	—	—	0.05	115	37.0	0.970	14.8	83 000	98 000
	5	1.5	2.3	6.1	6.1	0.5	0.6	0.08	189	51.0	1.35	13.3	74 000	87 000
	5	2	2.5	—	—	—	—	0.1	189	51.0	1.35	13.3	74 000	87 000
	6	2.3	3	7.5	7.5	0.6	0.8	0.15	310	89.0	2.37	12.8	67 000	79 000
	6	2.5	—	7.2	—	0.6	—	0.15	310	89.0	2.37	12.8	67 000	79 000
	7	2.5	—	—	—	—	—	0.15	430	120	3.20	11.9	59 000	70 000
	7	2.8	3.5	8.5	8.5	0.7	0.9	0.15	425	125	3.30	12.4	62 000	73 000
2.5	5	1.5	2.3	—	—	—	—	0.08	169	59.0	1.56	15.0	70 000	82 000
	6	1.8	2.6	7.1	7.1	0.5	0.8	0.08	231	73.0	1.92	14.2	65 000	76 000
	7	—	3	—	8.2	—	0.6	0.15	315	96.0	2.53	13.7	59 000	70 000
	7	2.5	3.5	8.5	8.5	0.7	0.9	0.15	315	96.0	2.53	13.7	59 000	70 000
	8	2.5	2.8	9.2	—	0.6	—	0.15	475	152	4.05	13.2	56 000	66 000
	8	2.8	4	9.5	9.5	0.7	0.9	0.15	610	174	7.05	11.5	56 000	66 000
3	6	2	2.5	7.2	7.2	0.6	0.6	0.08	268	94.0	2.47	14.7	60 000	71 000
	7	2	3	8.1	8.1	0.5	0.8	0.1	430	130	3.45	12.9	58 000	68 000
	8	2.5	—	9.2	—	0.6	—	0.15	620	180	7.25	11.9	54 000	63 000
	8	3	4	9.5	9.5	0.7	0.9	0.15	620	180	7.25	11.9	54 000	63 000
	9	2.5	4	10.2	10.6	0.6	0.8	0.15	700	219	8.85	12.4	50 000	59 000
	9	3	5	10.5	10.5	0.7	1	0.15	700	219	8.85	12.4	50 000	59 000
	10	4	4	11.5	11.5	1	1	0.15	710	224	9.05	12.7	50 000	58 000
4	7	2	2.5	8.2	8.2	0.6	0.6	0.08	246	88.0	2.31	15.3	54 000	63 000
	8	2	3	9.2	9.2	0.6	0.6	0.08	440	140	5.65	13.9	52 000	61 000
	9	2.5	4	10.3	10.3	0.6	1	0.15	710	224	9.05	12.7	49 000	57 000
	10	3	4	11.2	11.6	0.6	0.8	0.15	720	235	9.50	13.3	46 000	55 000
	11	4	4	12.5	12.5	1	1	0.15	790	276	11.1	13.7	45 000	52 000
	12	4	4	13.5	13.5	1	1	0.2	1 080	360	14.4	12.8	43 000	51 000
	13	5	5	15	15	1	1	0.2	1 450	490	19.8	12.4	42 000	49 000
	16	5	5	—	—	—	—	0.3	1 940	680	23.1	12.4	37 000	44 000
5	8	2	2.5	9.2	9.2	0.6	0.6	0.08	241	91.0	2.39	15.8	49 000	57 000
	9	2.5	3	10.2	10.2	0.6	0.6	0.15	555	211	5.55	14.6	46 000	55 000
	10	3	4	11.2	11.6	0.6	0.8	0.15	790	276	11.1	13.7	45 000	52 000

1) Smallest allowable dimension for chamfer dimension r.

# Miniature and Small Size Ball Bearings

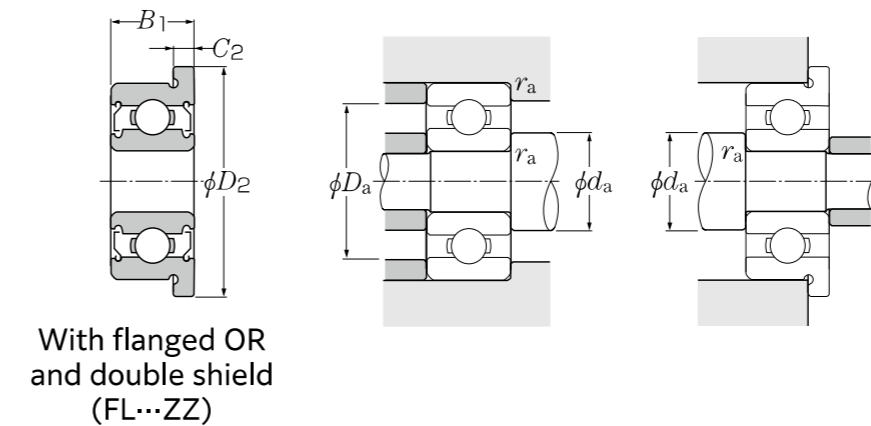

With flanged OR and double shield (FL...ZZ)

Dynamic equivalent radial load  
 $P_r = X F_r + Y F_a$

$\frac{f_0 \cdot F_a}{C_{0r}}$	e	$\frac{F_a}{F_r} \leq e$		$\frac{F_a}{F_r} > e$	
		X	Y	X	Y
0.172	0.19				2.30
0.345	0.22				1.99
0.689	0.26				1.71
1.03	0.28				1.55
1.38	0.30	1	0	0.56	1.45
2.07	0.34				1.31
3.45	0.38				1.15
5.17	0.42				1.04
6.89	0.44				1.00

Static equivalent radial load

$$P_{0r} = 0.6F_r + 0.5F_a$$

When  $P_{0r} < F_r$  use  $P_{0r} = F_r$ .

Open type	Bearing numbers					Installation-related dimensions mm				Mass (approx.) g	
	With single shield	With double shield	Open type with flange	With flanged OR and single shield	With flanged OR and double shield	Min. d <sub>a</sub>	Max. <sup>2)</sup> d <sub>a</sub>	r <sub>as</sub> Max.	Open type	Open type with flange	
68/1.5	W68/1.5SA	SSA	FL68/1.5	FLW68/1.5SA	SSA	2.3	2.4	3.2	0.05	0.07	0.09
69/1.5A	W69/1.5ASA	SSA	FL69/1.5A	FLW69/1.5ASA	SSA	2.7	2.9	3.8	0.15	0.18	0.24
60/1.5	W60/1.5ZA	ZZA	FL60/1.5	FLW60/1.5ZA	ZZA	2.7	3	4.8	0.15	0.35	0.42
672	—	—	—	—	—	2.5	2.6	3.5	0.05	0.06	—
682	W682SA	SSA	FL682	FLW682SA	SSA	2.8	2.9	4.2	0.08	0.13	0.17
BC2-5	WBC2-5SA	SSA	—	—	—	2.8	2.9	4.2	0.1	0.16	—
692	W692SA	SSA	FL692	FLW692SA	SSA	3.2	3.3	4.8	0.15	0.31	0.38
BC2-6	—	—	FLBC2-6	—	—	3.2	3.3	4.8	0.15	0.32	0.38
BC2-7A	—	—	—	—	—	3.2	3.6	5.8	0.15	0.44	—
602	W602ZA	ZZA	FL602	FLW602ZA	ZZA	3.2	3.7	5.8	0.15	0.54	0.64
67/2.5	W67/2.5ZA	ZZA	—	—	—	3.1	3.3	4.4	0.08	0.11	—
68/2.5	W68/2.5ZA	ZZA	FL68/2.5	FLW68/2.5ZA	ZZA	3.1	3.6	4.8	0.08	0.22	0.26
—	WBC2.5-7ZA	ZZA	—	FLWBC2.5-7ZA	ZZA	3.7	4	5.8	0.15	0.6 <sup>3)</sup>	0.67 <sup>3)</sup>
69/2.5	W69/2.5SA	SSA	FL69/2.5	FLW69/2.5SA	SSA	3.7	4	5.8	0.15	0.43	0.53
BC2.5-8	WBC2.5-8ZA	ZZA	FLBC2.5-8	—	—	3.7	4.3	6.8	0.15	0.57	0.65
60/2.5	W60/2.5ZA	ZZA	FL60/2.5	FLW60/2.5ZA	ZZA	3.7	4.1	6.8	0.15	0.72	0.83
673	WA673SA	SSA	FL673	FLWA673SA	SSA	3.6	4.1	5.4	0.08	0.2	0.26
683	W683Z	ZZ	FL683	FLW683Z	ZZ	3.9	4.1	5.8	0.1	0.33	0.38
BC3-8	—	—	FLBC3-8	—	—	4.2	4.4	6.8	0.15	0.52	0.6
693	W693Z	ZZ	FL693	FLW693Z	ZZ	4.2	4.4	6.8	0.15	0.61	0.72
BC3-9	WBC3-9ZA	ZZA	FLBC3-9	FLAWBC3-9ZA	ZZA	4.2	5	7.8	0.15	0.71	0.79
603	W603Z	ZZ	FL603	FLW603Z	ZZ	4.2	5	7.8	0.15	0.92	1
623	623Z	ZZ	FL623	FL623Z	ZZ	4.2	5.2	8.8	0.15	1.6	1.8
674A	WA674ASA	SSA	FL674A	FLWA674ASA	SSA	4.6	5	6.4	0.08	0.28	0.35
BC4-8	WBC4-8Z	ZZ	FLBC4-8	FLWBC4-8Z	ZZ	4.8	5	6.8	0.08	0.38	0.46
684AX50	W684AX50Z	ZZ	FL684AX50	FLW684AX50Z	ZZ	5	5.2	7.8	0.1	0.67	0.76
BC4-10	WBC4-10Z	ZZ	FLBC4-10	FLAWBC4-10Z	ZZ	5.2	6	8.8	0.15	1	1.1
694	694Z	ZZ	FL694	FL694Z	ZZ	5.2	6.4	9.8	0.15	1.8	2
604	604Z	ZZ	FL604	FL604Z	ZZ	5.6	6.6	10.4	0.2	2.1	2.3
624	624Z	ZZ	FL624	FL624Z	ZZ	5.6	6.2	11.4	0.2	3.2	3.5
634	634Z	ZZ	—	—	—	6	7.6	14	0.3	5.1	—
675	WA675Z	ZZ	FL675	FLWA675Z	ZZ	5.6	6	7.4	0.08	0.32	0.4
BC5-9	WBC5-9Z	ZZ	FLBC5-9	FLWBC5-9Z	ZZ	5.2	6.1	7.8	0.15	0.55	0.63
BC5-10	WBC5-10Z	ZZ	FLBC5-10	FLAWBC5-10Z	ZZ	6.2	6.4	8.8	0.15	0.88	0.97

2) This dimension applies to sealed and shielded bearings. 3) Values for double shielded bearings are shown.